



# ETATRACK<sup>®</sup> 1000 *active*

## Installation guide



Before starting installation, please read installation guide carefully!

## 1. Safety references

### 1.1 General

This installation instruction contains fundamental references, which are to be considered for mounting and start-up. It is to be read therefore absolutely before assembly and start-up from the mechanic as well as the responsible user, too. It should be at the installation site. This installation guide refers to the tracking system ETATRACK 1000 active. There is not only under this section of "safety references" the specified to consider general safety reference but also into other sections inserted, special safety reference.

### 1.2 Reference markings



Safety references marked with this symbol can cause endangerments of persons.

Attention

Safety references marked with this symbol can cause damages on machines or its function.

Advice

Advices and information to facilitate working and secure perfect operational sequences.

## 1.3 Training and qualification of the personnel

The personnel for installation, use and maintenance must exhibit the appropriate qualification for the work. Area of responsibility, competence and monitoring of the personnel must be exactly regulated by the user.

## 1.4 Safe working

All security references, present national instructions for accident prevention as well as internal instructions for working, use and safety are to be followed.

## 1.5 Consequences

In case of ignoring the security references, endangerments of persons, environment and the tracking system as well as total loss of requirement on compensation can be the consequence .

For example:

- Failure of important functions of the plant
- Endangerments of persons caused by mechanical effects.

## 1.6 Safety references for the user

Endangerments of electronic electricity are to be excluded. (see details for example in the regulation of Verband der Elektronik = VDE, Germany).

## 1.7 Safety references for installation and maintenance

Before starting work at the tracking system make sure that the electricity supply has been switched off. Please follow the instructions to stop the drive in this guide.

## 1.8 Inappropriate treatment

Working security of tracking systems is only guaranteed in case of normal application.

The limit values specified in the technical data are not to be exceeded!

## 2. Delivery and storage

### 2.1 Delivery

Tracking systems ETATRACK active are supplied completely from the factory.

Due to high weight of each part of the construction care must be taken during unpacking and handling.



It is absolutely necessary to wear security gloves and shoes!

## 3. Delivery contents

### 3.1 Mechanical parts:

-Mounting Pole	(1 pc)	Square tube	150x150x6, 2500 mm length	(1a)
-Beam	(1 pc)	Rectangular tube	150x100x6, 2500 mm length	(1b)
-Cross Beam	(1 pc)	Rectangular tube	150x100x6, 1000 mm length	(2)
-Centre rail	(4 pcs)	Square tube	50x50x4, 3400 mm length	(7)
-Connecting tube	(2 pcs)	Square tube	40x40x4, 2500 mm length	(8)

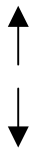

Parts NOT INCLUDED in DIY-Kit



Parts INCLUDED in DIY-Kit

-Pole connector	(4 pcs)	Steel angle	63x63x6, 280 mm length	(3)
-Cross Beam con.	(2 pcs)	Steel angle	63x63x6, 330 mm length	(3a)
-Hinge fixation	(3 pcs)	Steel angle	63x63x6, 213 mm length	(4)
-Hinge lower part	(4 pcs)	Welded steel	200x70x120 mm	(5)
-Hinge upper part	(4 pcs)	Welded steel	150x50x30 mm	(6)
-Connection clamp	(7 pcs)	Steel angle	40x40x4, 70mm length	(9)
-Upper motor fixation	(1 pc)	Steel angle	50x50x5, 70 mm length	(10)
-Lower motor fixation	(1 pc)	Steel angle	276x276, 63x63mm	(11)
-Module fixation clamp	(40 pcs)	Stainless steel	50x50x1,2mm	(12)
-Standard parts	(1 set)	Bolts, washers, nut		
-Linear motor	(1 pc)			(13)
-Controller fixation	(2 pcs)			(14)

### 3.2 Controller

- Electronic box incl. Lead Acid Battery and Controller	(15)
---	------

## 4. Assembly preparation

### 4.1 Foundation

Before mounting the tracking system a suitable foundation is necessary. A surface foundation for the tracking system has to be constructed to assure the correct operation for the indicated maximum of module surfaces (see fig. 4.1)

#### Advice

While setting mounting pole into foundation (1) take care of the exact adjustment of cross holes into EAST – WEST direction!

To get the right adjustment use some helping material (see figure hereunder).

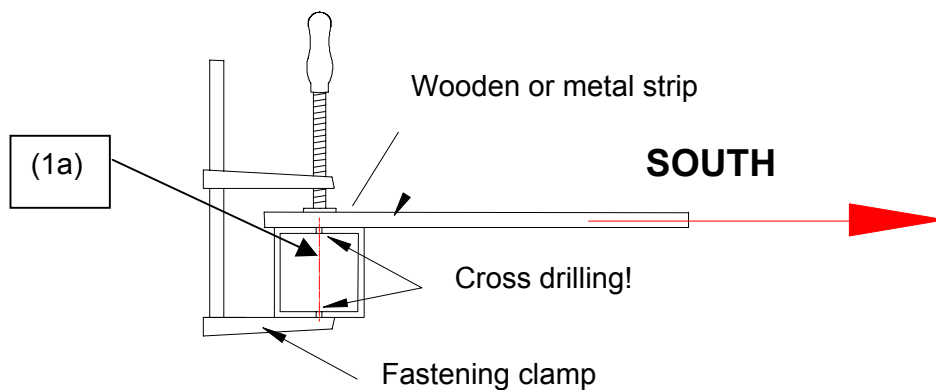

During drying-procedure of foundation please use wooden boards to support mounting pole.  
In case of installation on flat roofs, stability can be effected with clamping belts.

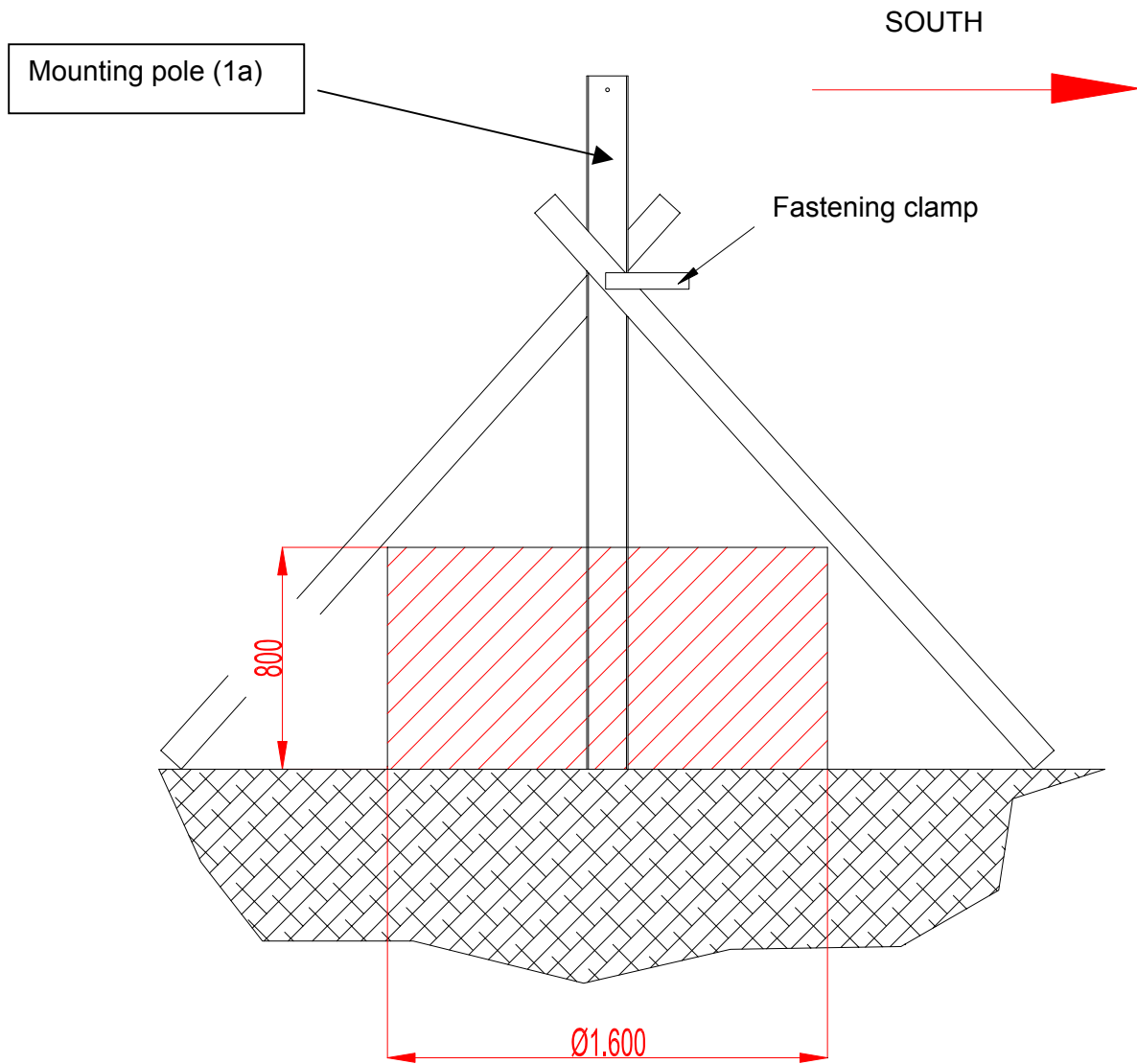

fig. 4.1 Dimensions of surface foundation



## 5. Mounting

### 5.1 Required tools:

- 2x ring or open ended flat spanner 24mm
- 2x ring or open ended flat spanner 10 / 13mm
- Level
- Rubber or plastic hammer
- Fastening clamp

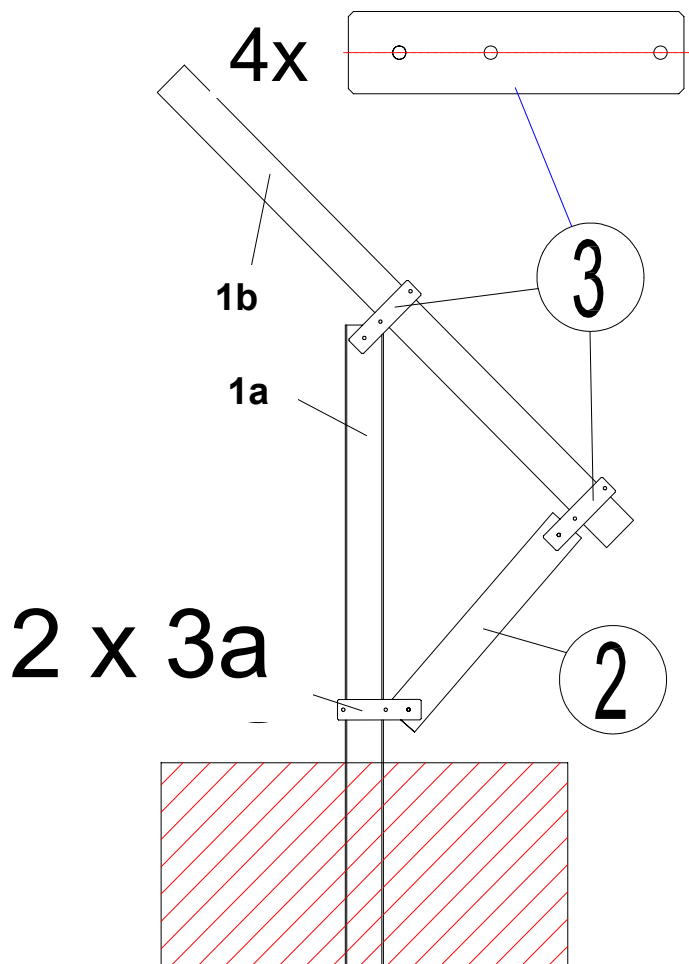

### 5.2. Hardened foundation:

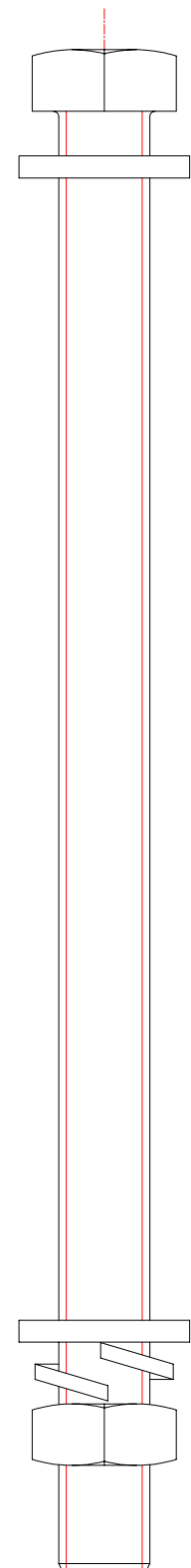

9x  
M16 x 190mm



## 5.3 Preparing the rails and hinges

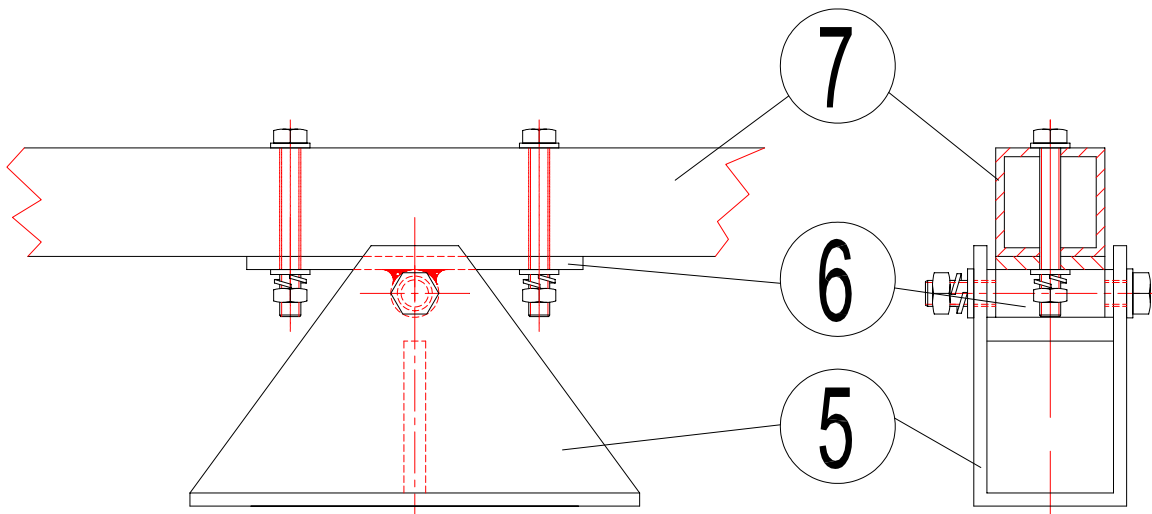

1 pc M12 x 95mm

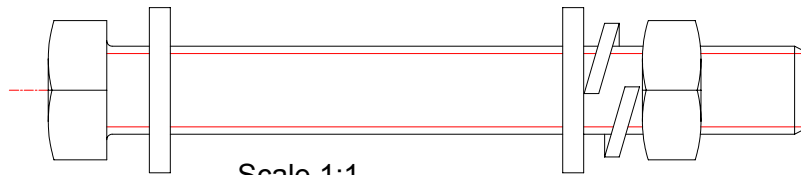

2 pcs M10 x 80mm

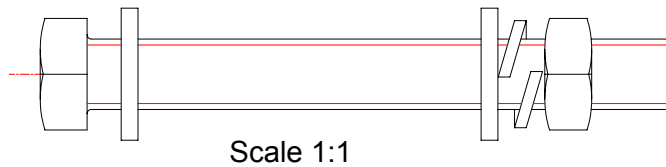

## 5.4 Fixation of rails on the beam

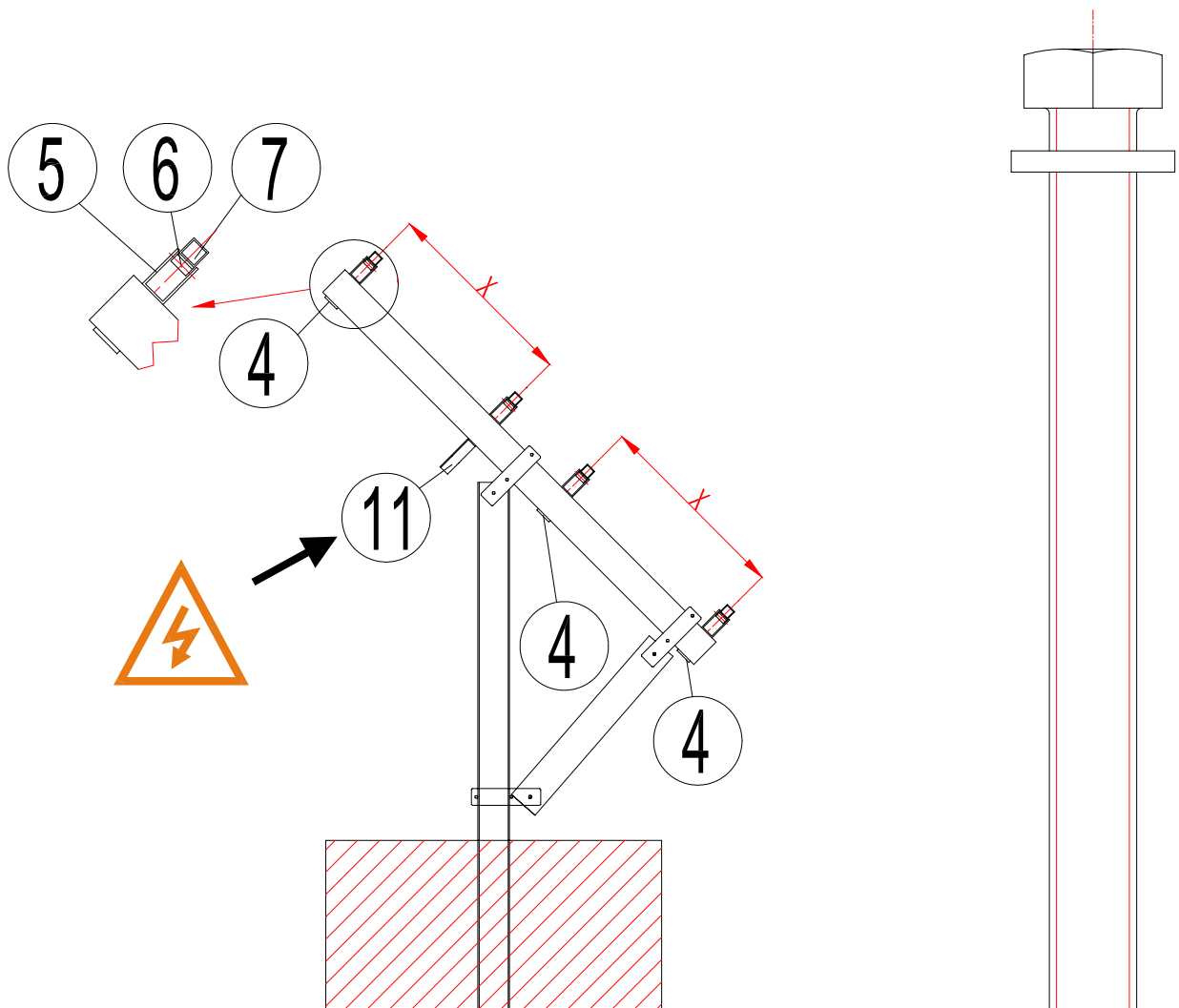

### Advice

Keep attention of lower mounting plate for drive (11)!!

Attachment of second upper cross beam deviates from the other three cross beams! (See fig. 5.4)

Before tightening the screws align module fixation in parallel line

Dimension „X“: depends on position of fixation holes in the PV modules.

X = Distance between holes - 110mm

8pcs  
M12 x 140

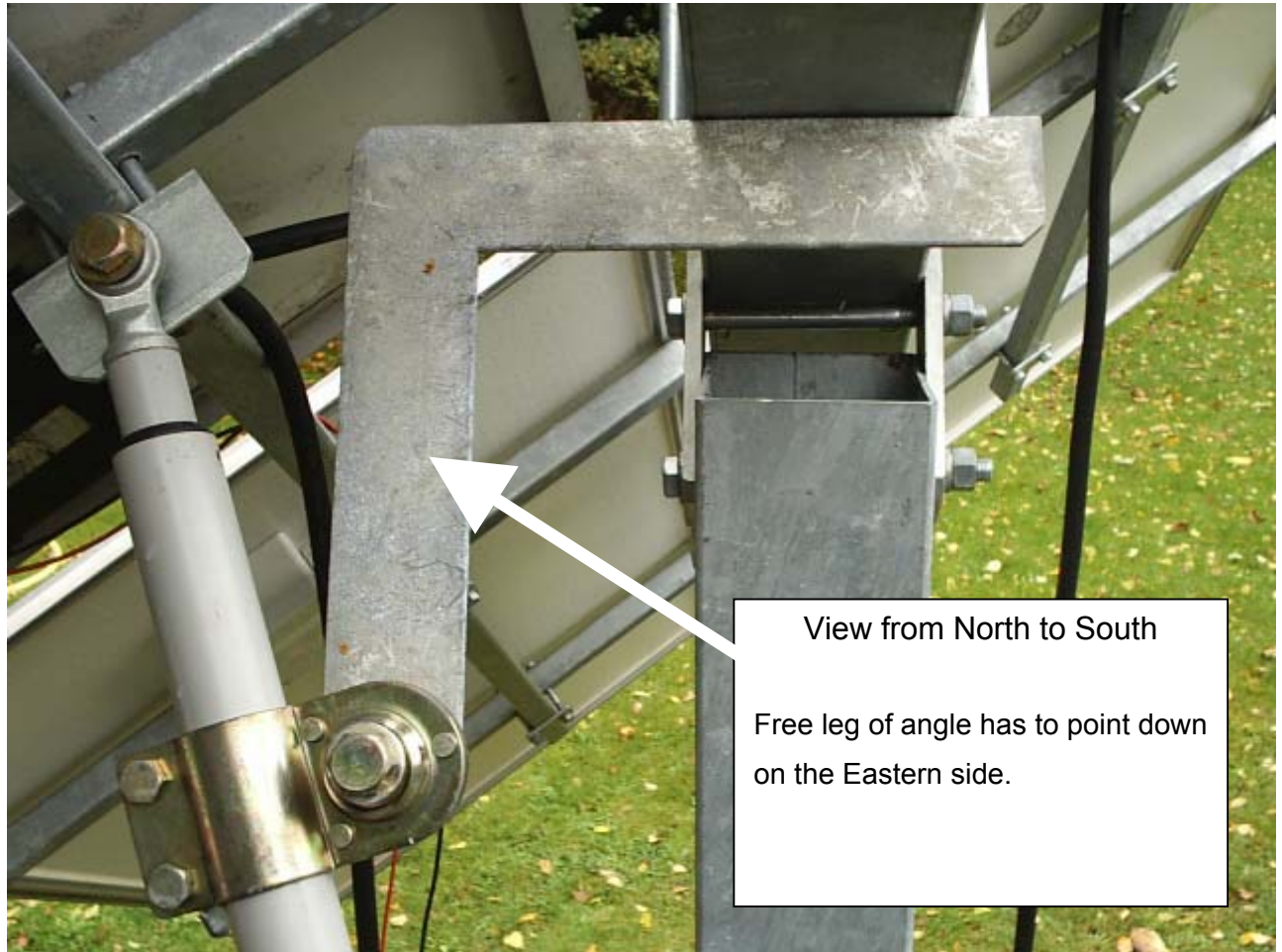

Fig. 5.4 Arrangement of lower motor fixation

## 5.5 Mounting of solar modules

Each solar module is to be fastened with 4 pcs fixation clamps(12) at the Centre rails (7). Please start with the following steps:

- Attach the fixation clamps on the module fixations
- Put in the screws M8 x 110 mm from the top into the drillings given at the module fixation
- Connect the centre rails with connecting tubes (8), connection clamps (9) as well as upper motor fixation (10).
- Fixation of solar modules

**Advice**

Before final tightening of screws please check easy swivelling feature. In case of difficulties the adjustment of the mounting poles could be not correct. The module frame has to be aligned right-angled.

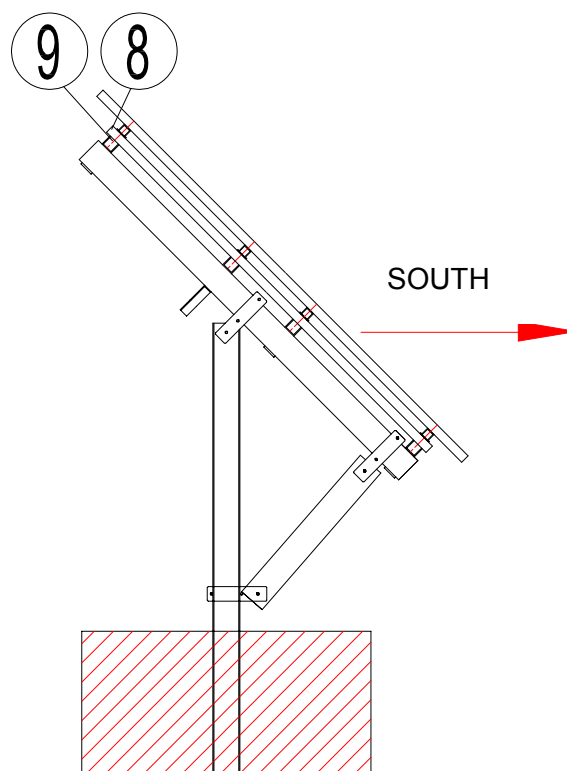



## 5.6. Assembly of linear motor

**Advice**

The linear motor is in factory setting, which means in morning position.  
Do not turn the inside bar with the ball!

During assembly of the motor on the frame:

Dimension (210 mm) must be kept!

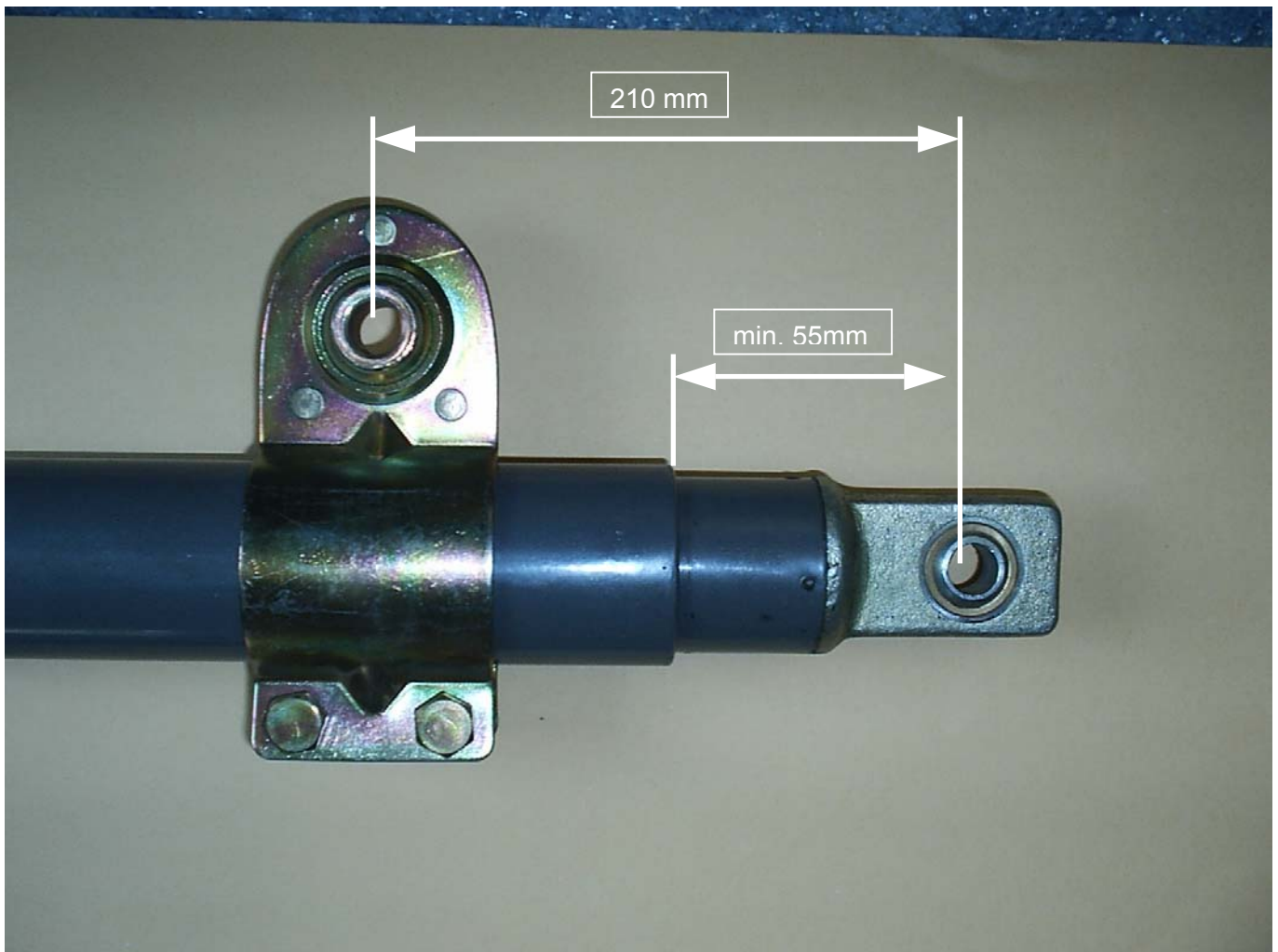

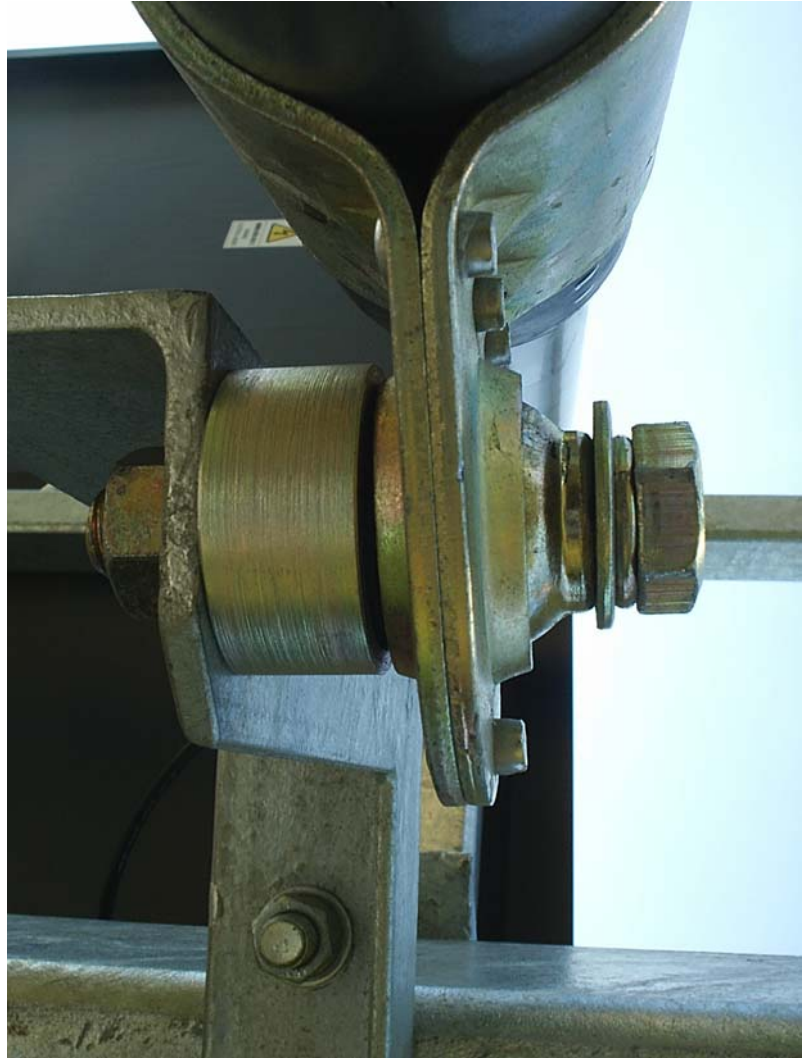

Lower motor fixation with spacer sleeve

Upper end of linear motor

