

**6** ENLARGED EAST ELEV. PORCH 1  
SCALE: 1/4" = 1'-0"

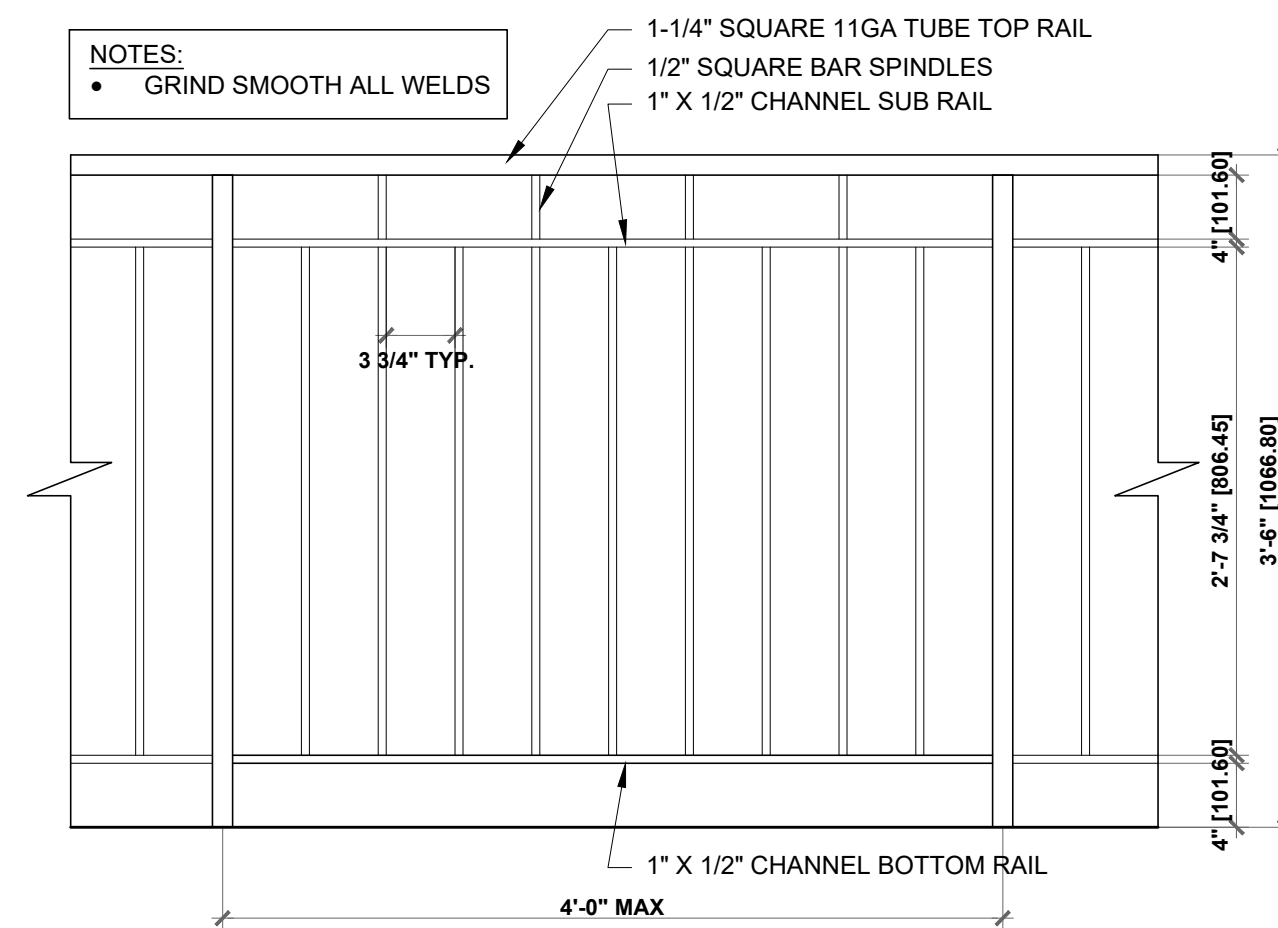

**8** GUARDRAIL ELEV. DET.  
SCALE: 1" = 1'-0"

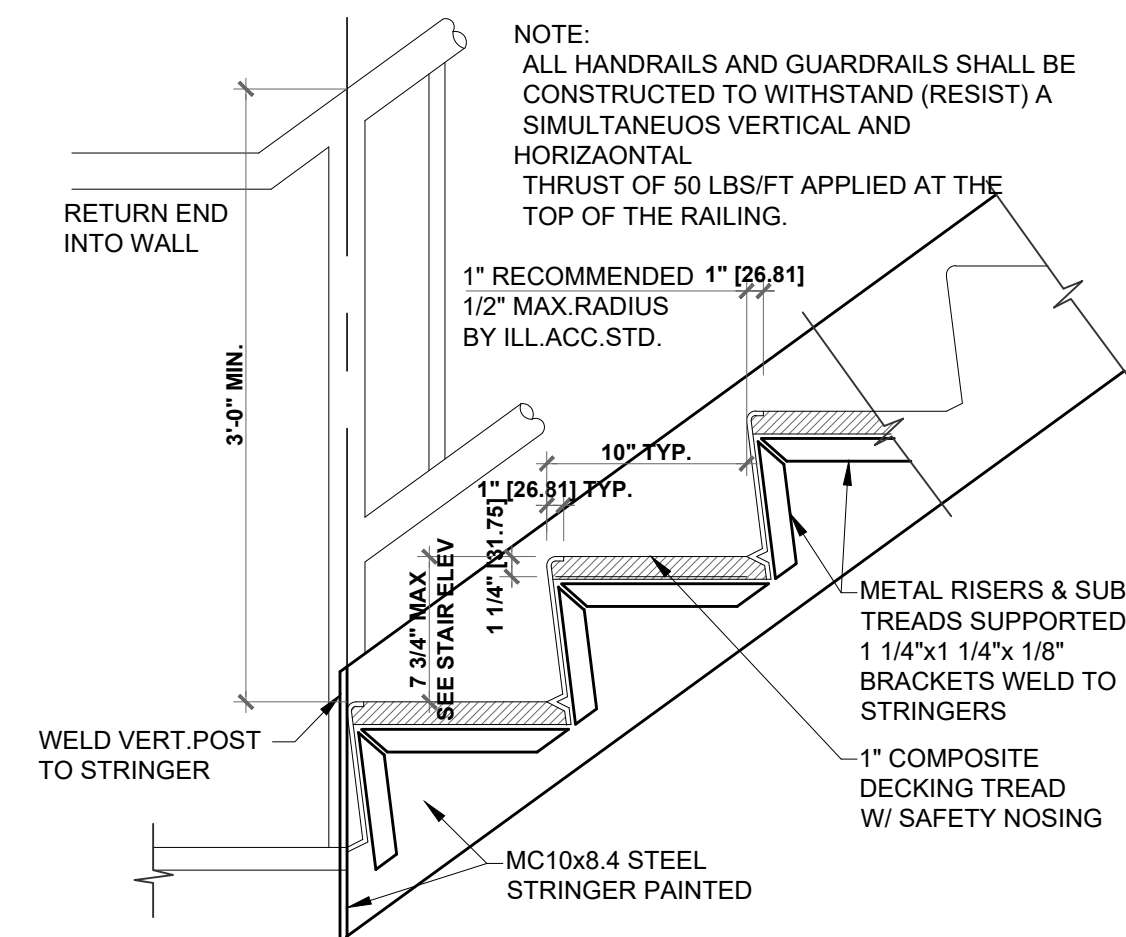

**7** HANDRAIL, TREAD & RISER DET.  
SCALE: 1" = 1'-0"

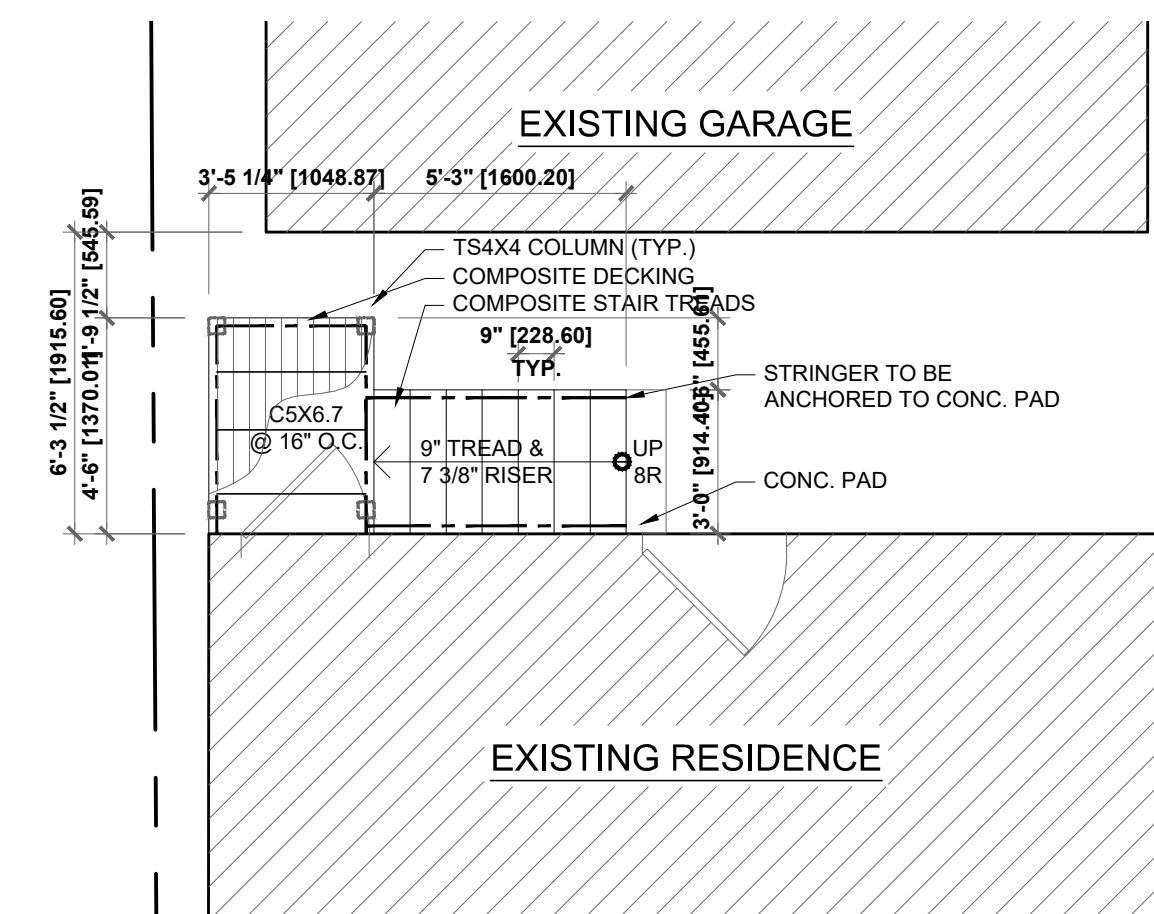

**2** FRAMING PORCH PLAN 2  
SCALE: 1/4" = 1'-0"

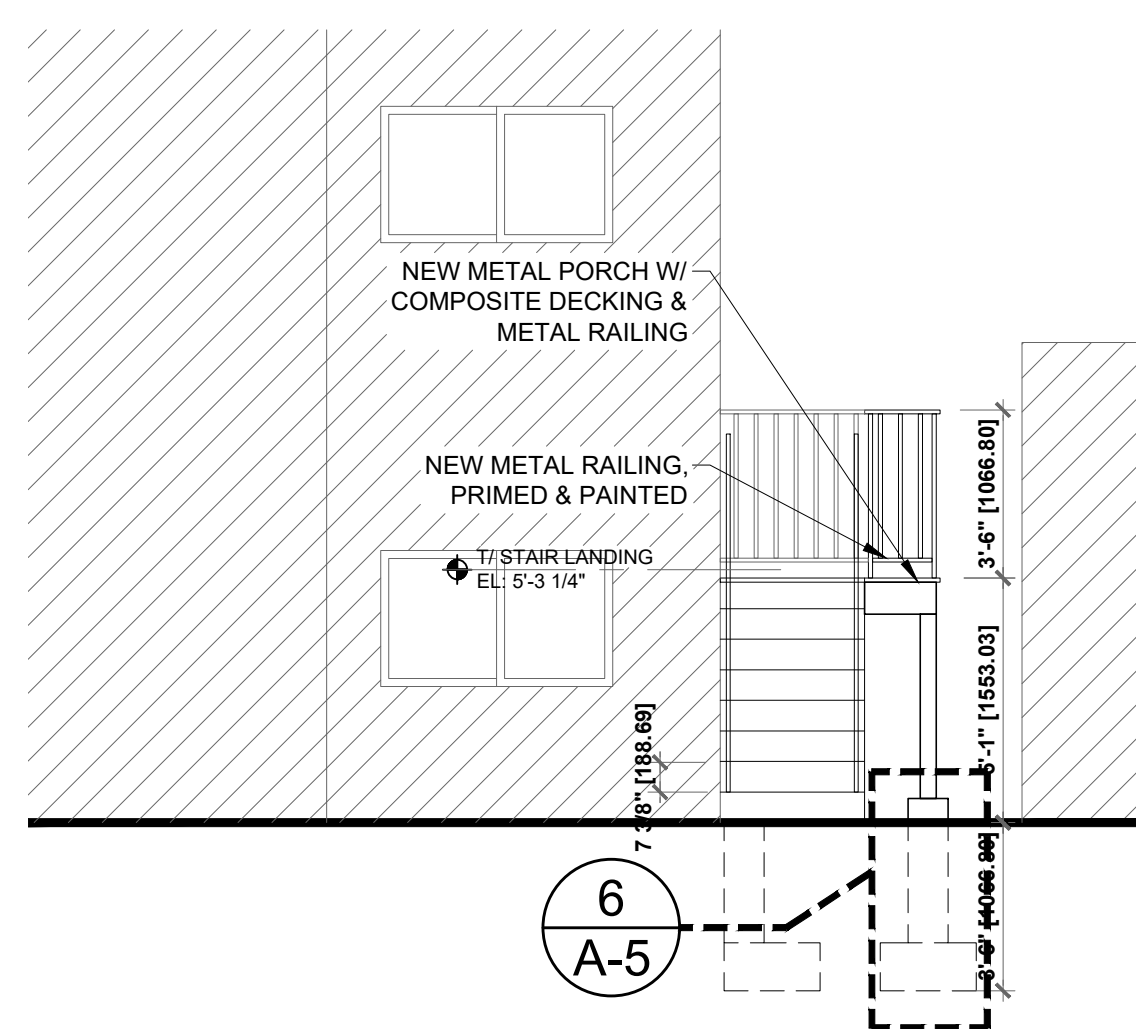

**5** EAST ELEV. PORCH 2  
SCALE: 1/4" = 1'-0"

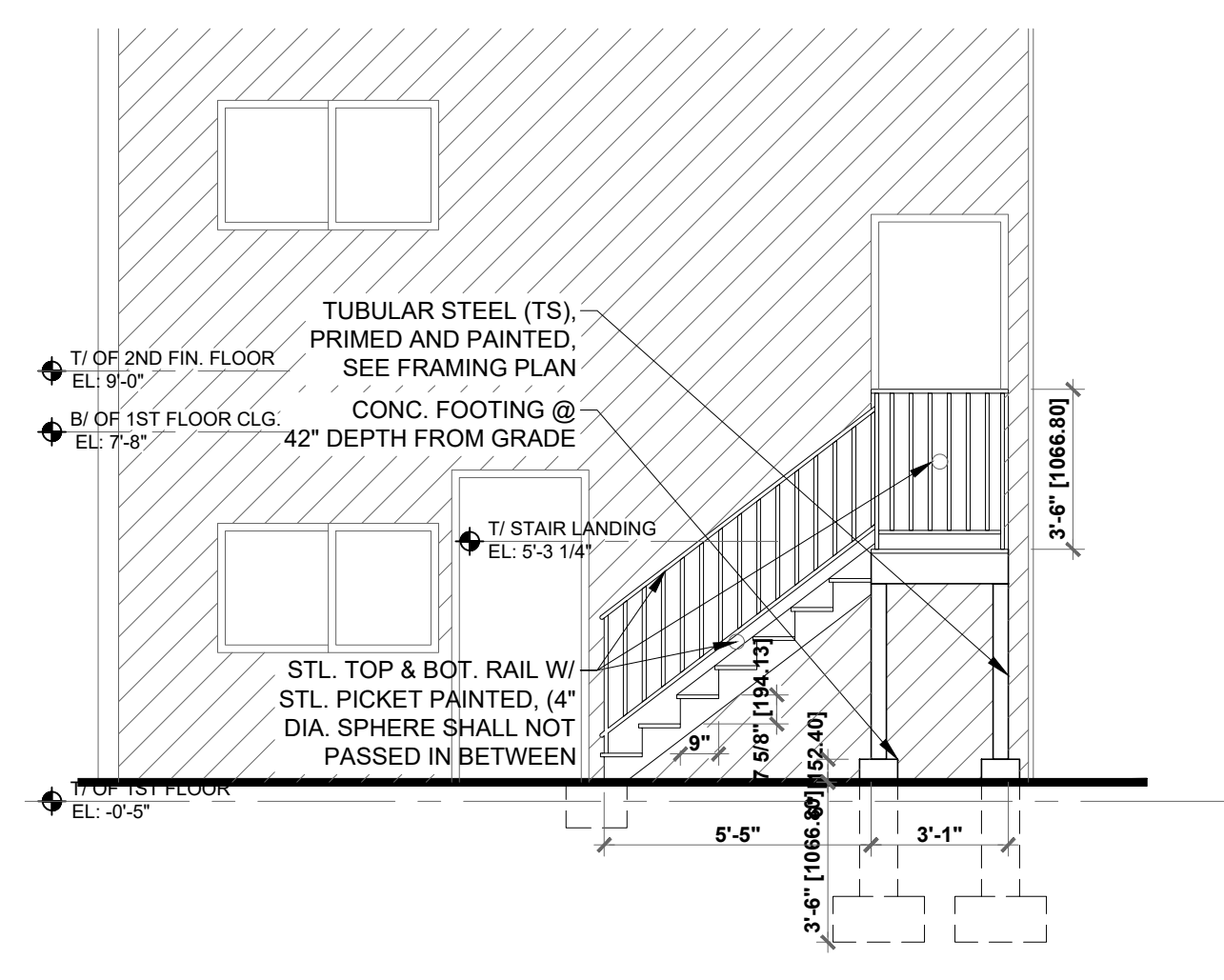

**4** NORTH ELEV. PORCH 2  
SCALE: 1/4" = 1'-0"

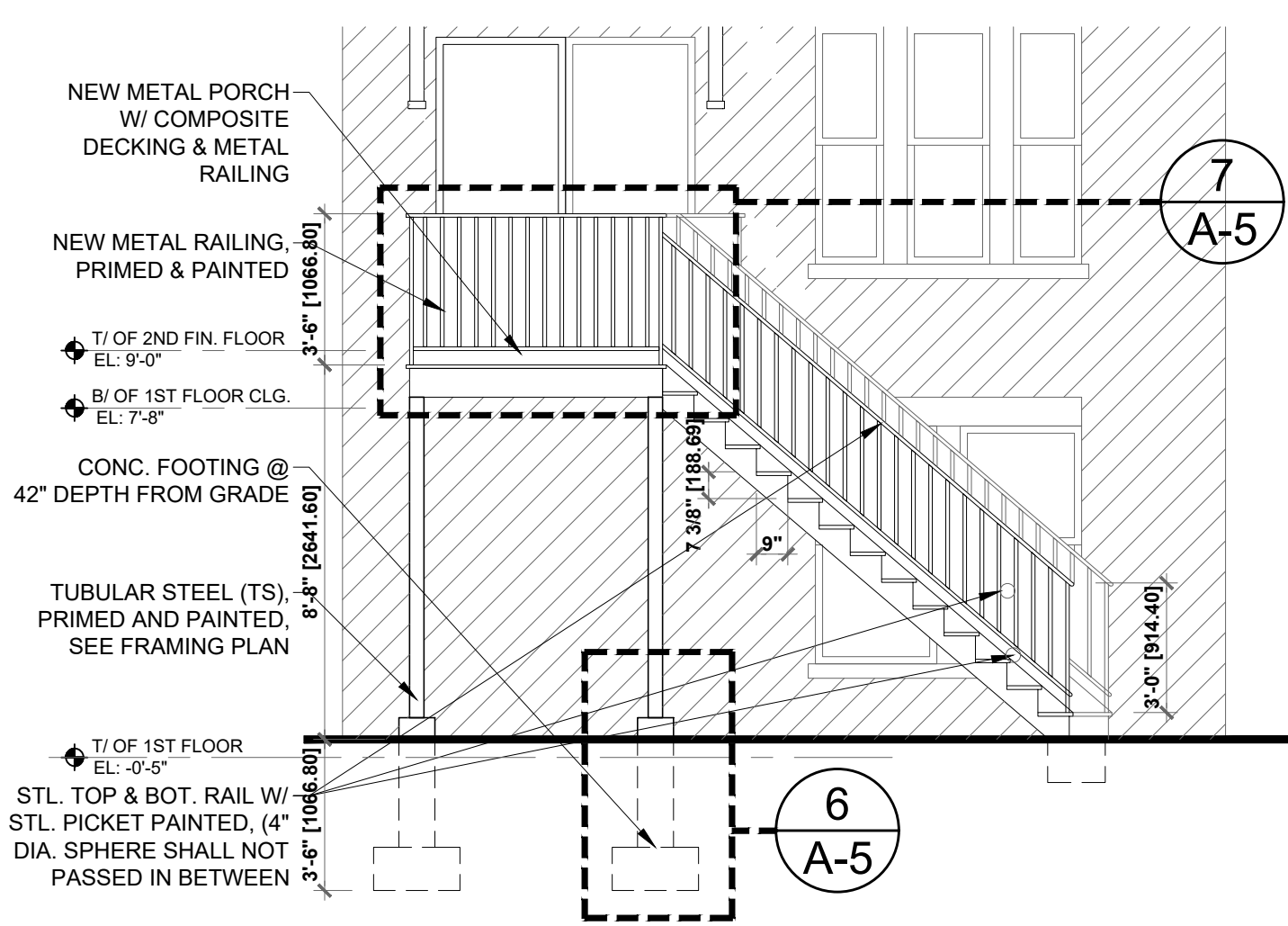

**3** SOUTH ELEV. PORCH 1  
SCALE: 1/4" = 1'-0"

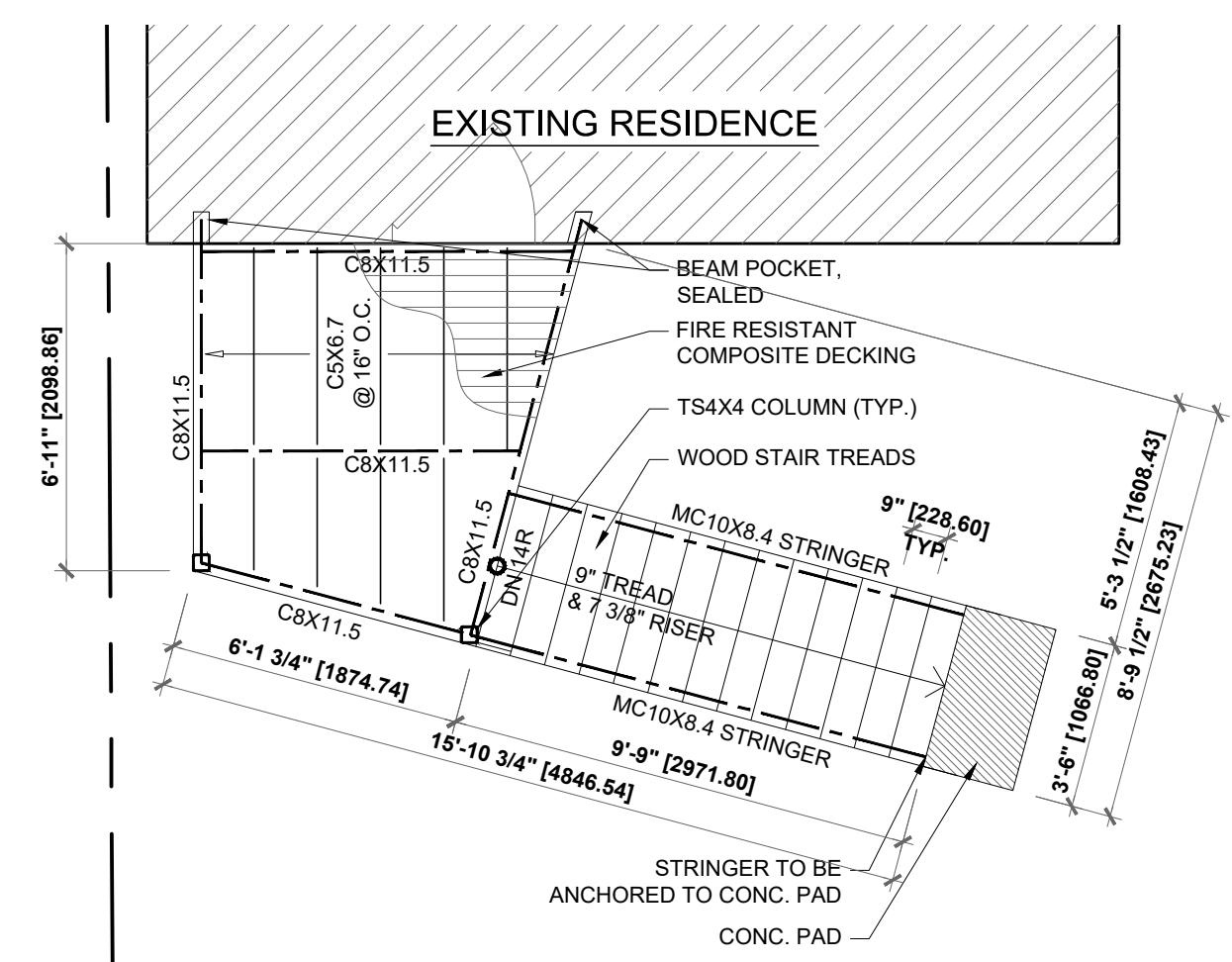

**1** FRAMING PORCH 1 PLAN  
SCALE: 1/4" = 1'-0"

12/26/15	OWNER REVIEW
----------	--------------

REVISIONS

**STAIRS PLANS, ELEV., SECT. DETAILS**  
**EXISTING RESIDENCE REMODELING**  
2544 W HADDON AVE. CHICAGO, IL 60622

STUDIO SAF, LTD  
1018 BUSSE HWY, PARK RIDGE IL, 60068  
TEL. 847-980-7440  
FAX. 847-255-5231  
WEB: studiosaf.com

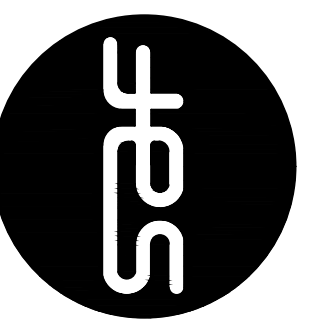

DATE 12.05.19

PROJECT NO

DRAWN AS SHOWN

SHEET

**SD-1**

COMPUTER FILE