

All-In-One Off-grid

Energy Storage System

ESS-5K1A-5KF1-A1

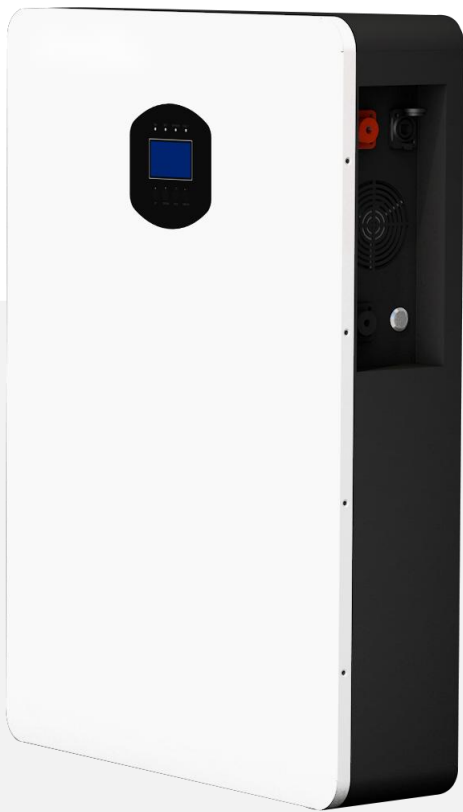

User
Manual

Table of Contents

- 1.Information 3
 - 1.1 System Introduction3
 - 1.2 Application 3
 - 1.3 Safety Instructions 3
 - 1.4 Battery Safety Datasheet 4
 - 1.5 General Precautions 5
 - 1.6 Parts List 6
 - 1.7 Specifications 6
 - 1.8 Liability Limitation 7
 - 1.9 Installation8
 - 1.10 Installation Site and Environment 8
- 2.Product Introduction 8
 - 2.1 Installation9
- 3.System Operation 10
 - 3.1 Switch On10
 - 3.2 Switch Off11
 - 3.3 AC Input/Output Connection 11
 - 3.4 PV Connection 12
 - 3.5 Dry Contact Signal13
 - 3.6 Wi-Fi Connection 13
 - 3.7 Emergency Procedure 14
- 4.Ems Introduction And Set Up15
 - 4.1 LCD Operating Figure15
 - 4.2 Operation Instructions for Query 16
 - 4.3 Other feature descriptions19
 - 4.4 Display Information30
 - 4.5 Operating Mode Description 31
 - 4.6 Warning Indicator32
 - 4.7 Fault Reference Code34
- 5.Routine Maintenance 36
 - 5.1 Maintenance Plan36
 - 5.2 Notes 36
- 6.Quality Assurance37

1.Information

1.1 System Introduction

ESS-5K1A-5KF1-A1(including Pack 5.12KWh and 5KF1)can be used in DC coupled systems (mainly newly installed), Ac coupling system (mainly transformation) and off-grid system (mainly transformation, photovoltaic capacity increase), the scheme is as follows:

Solution	Configuration	
	Inverter	Battery
ESS-5K1A-5KF1-A1	5KW	5KWH

1.2 Application

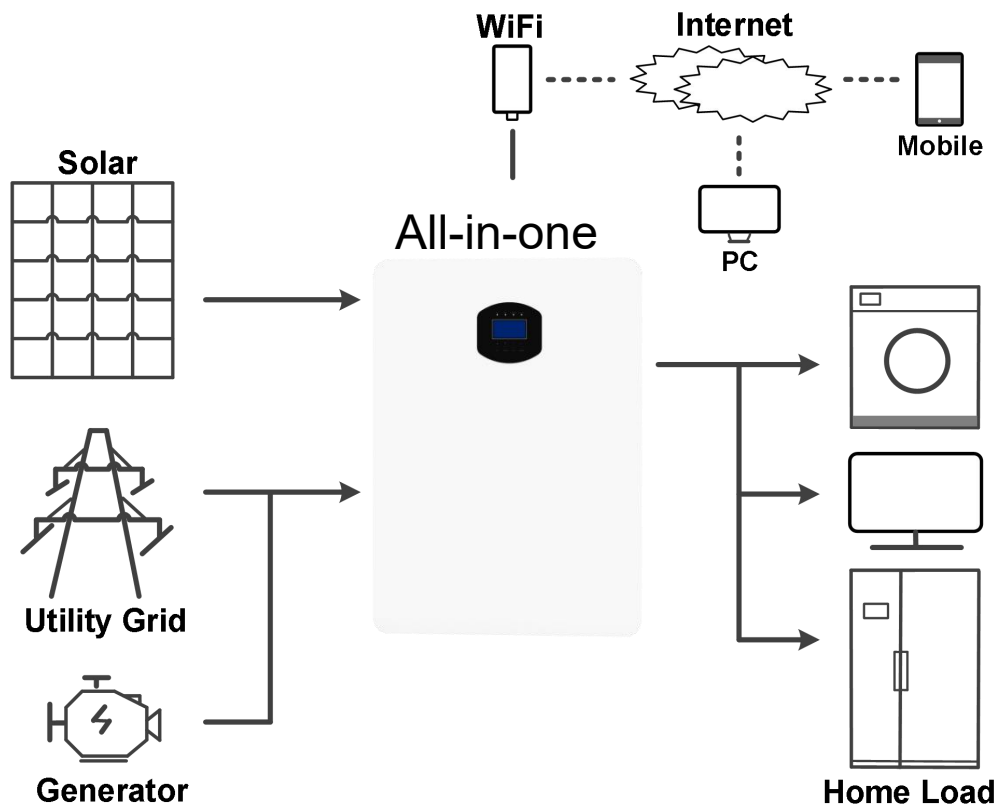

ESS-5K1A-5KF1-A1
Figure1 Working Diagram

1.3 Safety Instructions



1.3.1 This sign indicates a hazardous situation which, if not avoided, could result in death or serious injury.



1.3.2 The All-In-One must not be touched or put into service until 5 minutes after it has been

switched off or disconnected to prevent an electric shock or injury.



1.3.3 This sign shows danger of hot surface.



1.3.4 Refer to the operating instructions.

1.3.4. Setting of Warning Sign for Safety

During instruction, maintenance and repair, follow the instructions below to prevent non-specialist personnel from causing misuse or accident:

- ◆ Obvious signs should be placed at front switch and rear-level switch to prevent accidents caused by false switching.
- ◆ Warning signs or tapes should be set near operating areas.
- ◆ The system must be reinstalled after maintenance or operation.

1.3.5 Measuring Equipment

To ensure the electrical parameters to match requirements, related measuring equipment are required when the system is being connected or tested.

Ensure that the connection and use matched specification to prevent electric arcs or shocks.

1.3.6 Moisture Protection

It is very likely that moisture may cause damages to the system. Repair or maintaining activities in wet weather should be avoided or limited.

1.3.7 Operation After Power Failure

The battery system is part of the energy storage system which stores life-threatening high voltage even when the DC side is switched off. Touching the battery outlets is strictly prohibited. The inverter can keep a life-threatening voltage even after disconnecting it from the DC and / or AC side. Therefore, for safety reasons, it must be tested with a properly calibrated voltage tester before an installer works on the equipment.

1.4 Battery Safety Datasheet

1.4.1 Hazard Information

Classification of the hazardous chemical:

Exempt from classification according to Australian WHS regulations.

Other hazards:

This product is a Lithium Iron Phosphate Battery with certified compliance under the UN Recommendations on Transport of Dangerous Goods, Manual of Tests and Criteria, Part III, subsection 38.3. For the battery cell, chemical materials are stored in a hermetically sealed metal case, designed to withstand temperatures and pressures encountered during normal use. As a result, during normal use, there is no physical danger of ignition or explosion and chemical danger of hazardous materials' leakage.

However, if the product is exposed to a fire, added mechanical shocks, decomposed, added electric stress by misuse, the gas release vent will be operated. The battery cell case will be breached at the extreme. Hazardous materials may be released.

Moreover, if heated strongly by the surrounding fire, acrid or harmful fume may be emitted.

1.4.2 Safety Datasheet

For detailed information please refer to the provided battery safety datasheet.

1.5 General Precautions



DANGER

Danger to life due to high voltages of the PV array, battery and electric shock. When exposed to sunlight, the PV array generates dangerous DC voltage which will be present in the DC conductors and the live components of the inverter. Touching the DC conductors or the live components can lead to lethal electric shocks. If you disconnect the DC connectors from the system under load, an electric arc may occur leading to electric shock and burns.

- ◆ Do not touch uninsulated cable ends.
- ◆ Do not touch the DC conductors.
- ◆ Do not open the inverter and battery.
- ◆ Do not wipe the system with damp cloth.
- ◆ Have the system installed and commissioned by qualified people with the appropriate skills only.
- ◆ Prior to performing any work on the inverter or the battery pack, disconnect the inverter from all voltage sources as described in this document.



WARNING

Risk of chemical burns from electrolyte or toxic gases. During standard operation, no electrolyte shall leak from the battery pack and no toxic gases shall form. Despite careful construction, if the Battery Pack is damaged or a fault occurs, it is possible that electrolyte may be leaked or toxic gases formed.

- ◆ Do not install the system in any environment of temperature below -10°C or over 50°C and in which humidity is over 90%.
- ◆ Do not touch the system with wet hands.
- ◆ Do not put any heavy objects on top of the system. Do not damage the system with sharp objects.
- ◆ Do not install or operate the system in potentially explosive atmospheres or areas of high humidity.
- ◆ Do not mount the inverter and the battery pack in areas containing highly flammable materials or gases.
- ◆ If moisture has penetrated the system (e.g. due to a damaged enclosure), do not install or operate the system.
- ◆ Do not move the system when it is already connected with battery modules. Secure the system to prevent tipping with restraining straps in your vehicle.
- ◆ The transportation of product must be made by the manufacturer or an instructed personal. These instructions shall be recorded and repeated.

- ◆ A certified ABC fire extinguisher with minimum capacity of 2kg must be carried along when transporting.
- ◆ It is totally prohibited to smoke in the vehicle as well as close to the vehicle when loading and unloading.
- ◆ For the exchange of a battery module, please request for new hazardous goods packaging if needed, pack it and let it be picked up by the suppliers.
- ◆ In case of contact with electrolyte, rinse the affected areas immediately with water and consult a doctor without delay.



CAUTION:





Risk of injury through lifting or dropping the system. The inverter and battery are heavy. There is risk of injury if the inverter or battery is lifted incorrectly or dropped during transport or when attaching to or removing from the wall.

- ◆ Lifting and transporting the inverter and battery must be carried out by more than 2 people.

1.6 Parts List

Check the following parts list to ensure it is complete.

factory delivers a total system separately on site to client, this consists of:

 <p>All-In-One OFF-GRID Energy Storage System</p>	 <p>WIFI module</p>
 <p>APP Operation Guide</p>	 <p>User manual</p>

1.7 Specifications

All-In-OneESS		
Item	Model	5KWh+5KW
Battery Module	Voltage	51.2V
	Battery capacity	100Ah
	Charge voltage	58V

	Discharge cut-off voltage	42V
	Charge current	50A
	Max charge current	100A
	Discharge current	100A
	Max discharge current	100A
	Max peak current	200A
	Communication method	RS485/CAN
Hybrid Inverter	Power	5KW
	Output Voltage	230VAC
	Frequency	50Hz/60Hz
	input power (PV)	5KW
	Input voltage range (PV)	120~430VDC
	Communication connect port	WiFi (optiona))
Parameter	Protection Degree	IP21
	Material/Colour	Metal/White
	Size	500*170*720mm
	Weight	56Kg
	Temperature	Charge:0°C-50°C Discharge;-15°C-60°C

1.8 Liability Limitation

Any product damage or property loss caused by the following conditions, factory does not assume any direct or indirect liability.

Product modified, design changed or parts replaced without factory authorization;

Changes, repair attempts and erasing of series number or seals by non factory technician;

System design and installation are not in compliance with standards and regulations;

Fail to comply with the local safety regulations (VDE for DE, SAA for AU);

Transport damage (including painting scratch caused by rubbing inside packaging during shipping). A claim should be made directly to shipping or insurance company in this case as soon as the container/packaging is unloaded and such damage is identified;

Fail to follow any/all of the user manual, the installation guide and the maintenance regulations;
Improper use or misuse of the device;
Insufficient ventilation of the device;
The maintenance procedures relating to the product have not been followed to an acceptable standard;
Force majeure (violent or stormy weather, lightning, overvoltage, fire etc.); Damages caused by any external factors.

1.9 Installation

This Manual introduces the basic steps to install and set up product



NOTE:
Please be cautious unpacking the battery, otherwise components could be damaged.

1.10 Installation Site and Environment

General

This energy storage system is indoor version and can be installed in an indoor location.

When product systems are installed in a room, product must not be hampered by the structure of the building, the furnishings and equipment of the room.

The product is naturally ventilated. The location should therefore be clean, dry and adequately ventilated.

The mounting location must allow free access to the unit for installation and maintenance purposes, and the system panels must not be blocked.

The following locations are not allowed for installation:

habitable rooms;

ceiling cavities or wall cavities;

on roofs that are not specifically considered suitable;

access / exit areas or under stairs / access walkways;

where the freezing point can be reached, such as garages, carports or other places as well as wet rooms (environmental category 2);

locations with humidity and condensation over 90%;

places where salty and humid air can penetrate;

seismic areas - additional security measures are required;

Sites with altitude below 2000m;

places with an explosive atmosphere;

locations with direct sunlight or a large change in the ambient temperature;

places with flammable materials or gases or an explosive atmosphere.

2. Product Introduction

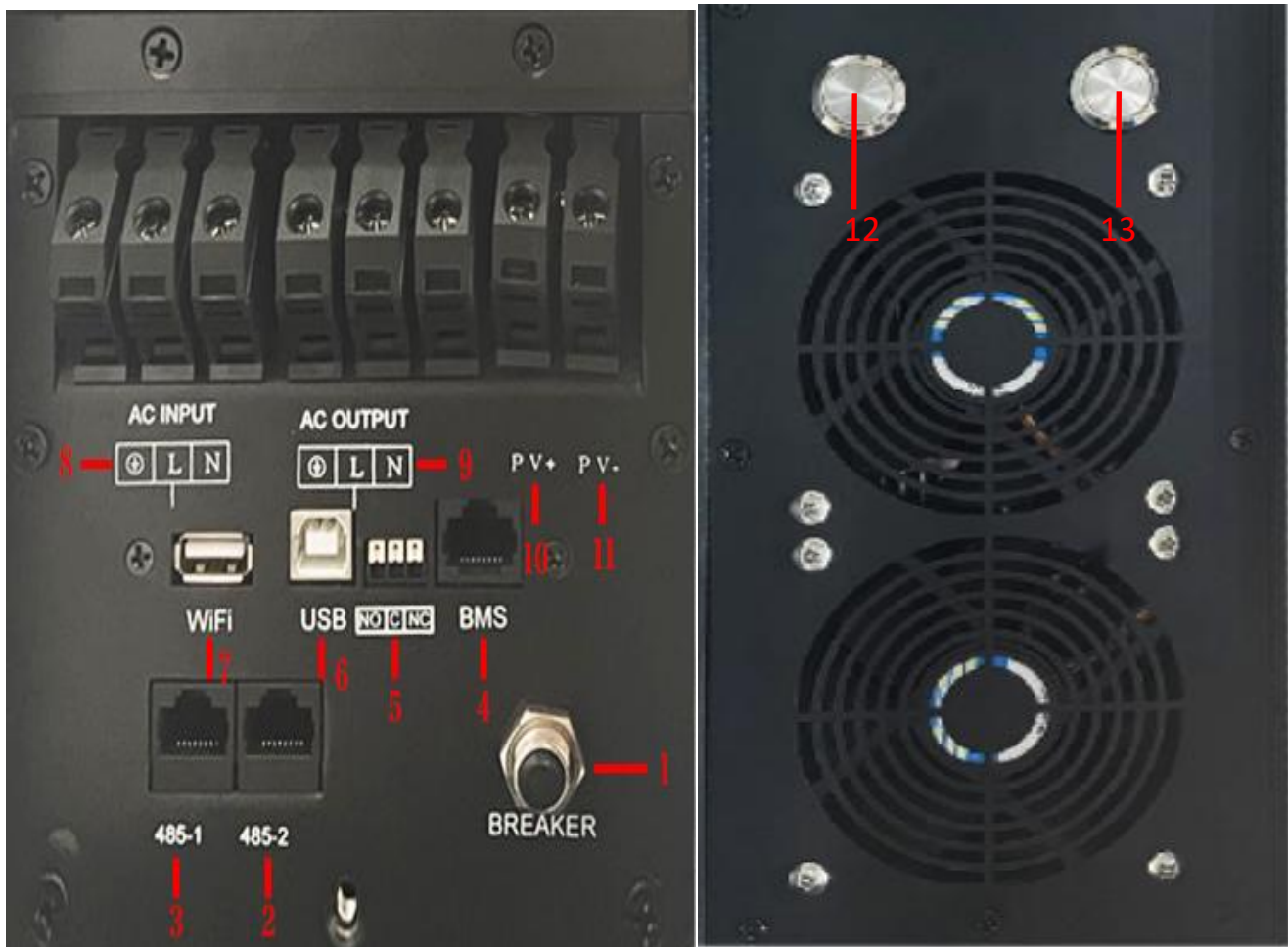

NO	NAME	Silk-SCREEN	REMARK
1	Breaker	Breaker	/
2	485-1	AC OUT	AC OUTPUT
3	485-2	WiFi	/
4	BMS	USB	/
5	Dry Contact	NO/C/NC	/
6	USB	USB	/
7	WiFi	WiFi	/
8	AC IN	AC IN	AC input
9	AC OUT	AC OUT	AC OUTPUT
10	PV IN	PV IN	PV+
11	PV IN	PV IN	PV-
12	SW	SW	battery switch
13	SW	SW	Inverter switch

2.1 Installation

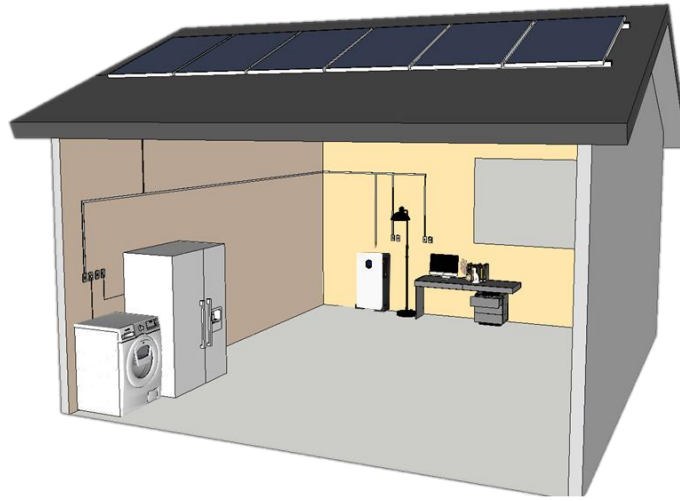

Household off-grid application



NOTE: First turn on the battery switch, then turn on the inverter switch.



NOTE: Recommended AC circuit breaker rating is 32A.



STATEMENT: The method of anti-islanding protection is Method(c)

3. System Operation

3.1 Switch On

When turning on the system, it is very important to follow the steps below to prevent damage to the system .

WARNING: Please check the installation again before turning on the system .



Step 1: Turn on the external PV switch.

Step 2: Turn on the external grid switch.

Step 3: If backup load is applied, turn on the external Backup switch.



NOTE:

the Backup switch is only used when a backup load is applied.

3.2 Switch Off

Step 1: Press the switch button of the inverter, and then press the power button of the battery until the display is off.

Step 2: Turn off the external grid switch.

Step 3: If backup load is applied, turn off the external backup switch.

Step 4: Turn off the external PV switch on the cable box.

3.3 AC Input/Output Connection

CAUTION: Before connecting to AC input power source, please install a separate AC breaker between inverter and AC input power source. This will ensure the inverter can be securely disconnected during maintenance and fully protected from over current of AC input. The recommended spec of AC breaker is 32A for 5KF1.

CAUTION: There are two terminal blocks with ‘IN’ and ‘OUT’ markings. Please do NOT mis-connect input and output connectors.

WARNING: All wiring must be performed by a qualified personnel.

WARNING: It’s very important for system safety and efficient operation to use appropriate cable for AC input connection. To reduce risk of injury, please use the proper recommended cable size as below.

Suggested cable requirement for AC wires

Model	Gauge	Torque Value
5KF1	1*8AWG	1.2-1.6 Nm

Please follow below steps to implement AC input/output connection:

Before making AC input/output connection, be sure to open DC protector or disconnecter first.

Remove insulation sleeve 10mm for six conductors. And shorten phase L and neutral conductor N 3 mm.

Insert AC input/output wires according to polarities indicated on terminal and tighten the terminal screws.

Be sure to connect PE protective conductor  first.

 → Ground (yellow)

L → LINE (black)

N → Neutral (red)

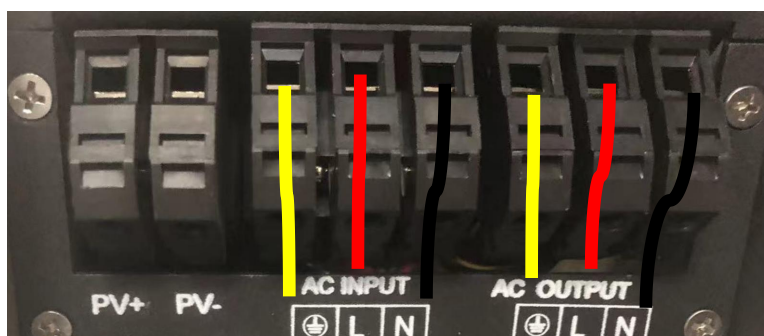

Connect the corresponding cable to the port according to the identifier , Make sure the wires are securely connected.

	<p>WARNING: Be sure that AC power source is disconnected before attempting to hardwire it to the unit.</p>
---	---

CAUTION: Important

Be sure to connect AC wires with correct polarity. If L and N wires are connected reversely, it may cause utility short-circuited when these inverters are worked in parallel operation.

CAUTION: Appliances such as air conditioner are required at least 2~3 minutes to restart because it's required to have enough time to balance refrigerant gas inside of circuits. If a power shortage occurs and recovers in a short time, it will cause damage to your connected appliances. To prevent this kind of damage, please check with manufacturer of air conditioner that if it's equipped with time-delay function before installation. Otherwise, this off grid solar inverter will trig overload fault and cut off output to protect your appliance but sometimes it still causes internal damage to the air conditioner.

3.4 PV Connection

CAUTION: Before connecting to PV modules, please install separately a DC circuit breaker between inverter and PV modules.

WARNING: All wiring must be performed by a qualified personnel.

WARNING: It's very important for system safety and efficient operation to use appropriate cable for PV module connection. To reduce risk of injury, please use the proper recommended cable size as below.

Model	Gauge	Torque Value
5KW	1*12AWG	1.2-1.6 Nm

PV Module Selection:

When selecting proper PV modules, please be sure to consider below parameters:

1. Open circuit Voltage (Voc) of PV modules not exceeds max. PV array open circuit voltage of inverter.
2. Open circuit Voltage (Voc) of PV modules should be higher than min. battery voltage.

Inverter Model	5KW
Max. PV Array Open Circuit Voltage	450Vdc
Start-up Voltage	150Vdc
PV Array MPPT Voltage Range	120Vdc~430Vdc

Please follow below steps to implement PV module connection:

Remove insulation sleeve 10 mm for positive and negative conductors.

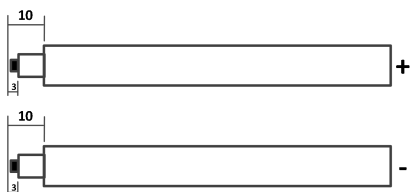

Step 1: Check the input voltage of PV array modules. This system is applied with One strings of PV array. Please make sure that the maximum current load of each PV input connector is 18A.

CAUTION: Exceeding the maximum input voltage can destroy the unit!! Check the system before wire connection.

Step 2: Disconnect the circuit breaker and switch off the DC switch.

Step 3: Insert PV+/PV- according to the polarity indicated on the terminal, and tighten the terminal screw.



Make sure the wires are securely connected.

3.5 Dry Contact Signal

There is one dry contact(3A/250VAC) available on the rear panel. It could be used to deliver signal to external device when battery voltage reaches warning level.

Unit Status	Condition		Dry Contact port:		
			NC & C	NC & C	
Power Off	Unit is off and no output is powered		Close	Open	
Power On	Output is powered from Utility		Close	Open	
	Output is powered from Battery or Solar	Program 01 is set as Utility first	Battery voltage(SOC) < Low DC warning voltage(SOC)	Open	Close
			Battery voltage(SOC) > Setting value in Program 13 or battery charging reaches floating stage	Close	Open
	Output is powered from Battery or Solar	Program 01 is set as SBU or Solar first	Battery voltage(SOC) < Setting value in Program 12	Open	Close
Battery voltage(SOC) > Setting value in Program 13 or battery charging reaches floating stage			Close	Open	

3.6 Wi-Fi Connection

This unit is equipped with a Wi-Fi transmitter. Wi-Fi transmitter can enable wireless communication between off-grid inverters and monitoring platform. Users can access and control the monitored inverter with downloaded APP. You may find “SmartESS” app from the Apple® Store or SmartESS Wi-Fi”

in Google® Play Store. All data loggers and parameters are saved in iCloud. For quick installation and operation, please refer to Appendix III - The Wi-Fi Operation Guide for details.

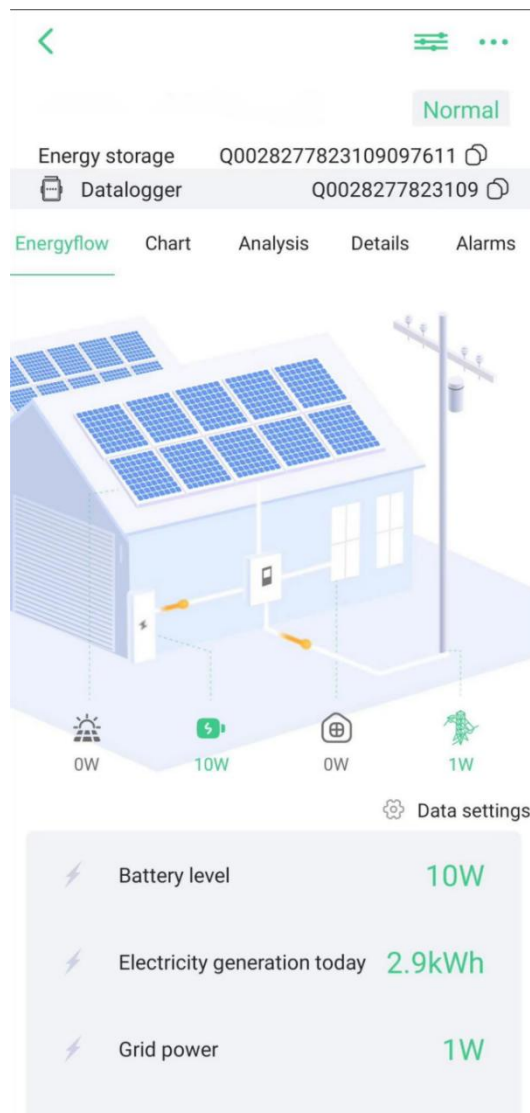

3.7 Emergency Procedure

When the energy storage system appears to be running abnormally, you can turn off the grid-connected main switch that directly feeding the BESS , and turn off all load switches within the BESS ,turn off the battery switch at the same time. To prevent a potentially fatal personal injury, if you want to repair or open the machine after the power is switched off,please measure the voltage at the input terminals with a suitably calibrated voltage tester.Before working on this equipment, please confirm that there is no grid electric supply to the BESS! The upper cover plate cannot be opened until the DC-link capacitance inside the battery modules discharges completely about 15 minutes later.

3.7.1 Emergency Handling Plan

1. Disconnect the AC breaker.
- 2.Check the control power supply. If it is OK, return the power supply to find out the reason.
3. Please record every detail related to the fault, so Factory can analyse and solve the fault. Any operation of equipment during a fault is strictly forbidden, please contact Factory as soon as possible.
- 4.As battery cells contain a little Oxygen inside and all cells have got explosion-proof valves,explosion hardly happens.

5. When the indicator light on the battery shows a red fault, check the fault type through the communication protocol, and contact our after-sales service personnel for advice.

3.7.2 Hazards

If the battery pack leaks electrolyte, avoid contact with the leaking liquid or gas.

If one is exposed to the leaked substance, immediately perform the actions described below:

Inhalation: Evacuate the contaminated area, and seek medical attention.

Eye contact: Rinse eyes with running water for 5 minutes, and seek medical attention.

Contact with skin: Wash the affected area thoroughly with soap and water, and seek medical attention.

Ingestion: Induce vomiting and seek medical attention.

3.7.3 Fire

If a fire breaks out in the place where the battery pack is installed, perform the following countermeasures:

Fire extinguishing media

During normal operation, no respirator is required. Burning batteries can not be extinguished with a regular fire extinguisher, this requires special fire extinguishers such as the Novec 1230, the FM-200 or a dioxin extinguisher. If the fire is not from a battery, normal ABC fire extinguishers can be used for extinguishing.

Fire -fighting instructions

1. If fire occurs when charging batteries, if it is safe to do so, disconnect the battery pack circuit breaker to shut off the power to charge.
2. If the battery pack is not on fire yet, extinguish the fire before the battery pack catches fire.
3. If the battery pack is on fire, do not try to extinguish but evacuate people immediately.



NOTE: There may be a possible explosion when batteries are heated above 150°C. When the battery pack is burning, it leaks poisonous gases. Do not approach.

Effective ways to deal with accidents

Battery in dry environment: Place damaged battery into a segregated place and call local fire department or service engineer.

Battery in wet environment: Stay out of the water and don't touch anything if any part of the battery, inverter, or wiring is submerged.

Do not use a submerged battery again and contact the service engineer.

4. Ems Introduction And Set Up

4.1 LCD Operating Figure

The operation and display panel, shown in below chart, is on the front panel of the inverter. It includes three indicators, four function keys and a LCD display, indicating the operating status and input/output power information.

1. LCD display
2. AC indicator
3. Inverter indicator
4. Charging indicator
5. Fault indicator
6. Function buttons

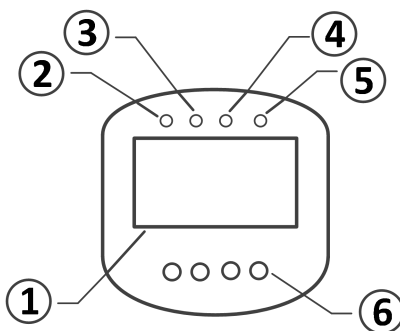

LED Indicator

LED indicator			Messages
AC	Green	Solid on	Output is powered by utility in Linde mode
		Flashing	Output is powered by battery or PV in battery mode
INV	Yellow	Solid on	Inverter work in battery mode
		Flashing	Inverter work in the other mode
CHG	Yellow	Solid on	Battery is fully charged
		Flashing	Battery is charging
FAULT	Red	Solid on	Fault occurs in the inverter
		Flashing	Warning condition occurs in the inverter

Function Buttons







Button	Description
ESC	To exit setting mode
UP	To go to previous selection
DOWN	To go to next selection
ENTER	To confirm the selection in setting mode or enter setting mode

4.2 Operation Instructions for Query

In normal display mode, if there are 10 pages of information displayed, you can use the UP or DOWN button to flip through the pages by pressing and holding for around 0.2-1 second. The corresponding query contents for each page are shown below:

Index	Function Code	Functionality	Function Display
1	P1	Inverter Input/Output Voltage	

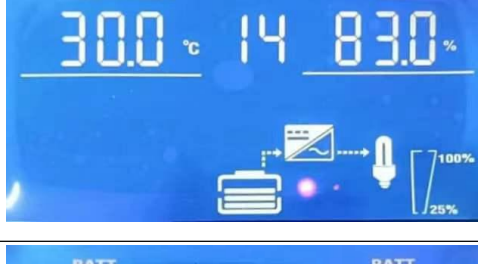

2	P2	Inverter Input/Output Frequency	
3	P3	Battery Voltage and Charging Current	
4	P4	PV Voltage and PV Charging Current	
5	P5	PV Voltage and PV Power	
6	P6	AC Output Voltage and Active Power	
7	P7	AC output voltage and complex power.	
8	P8	AC output voltage and load power percentage.	

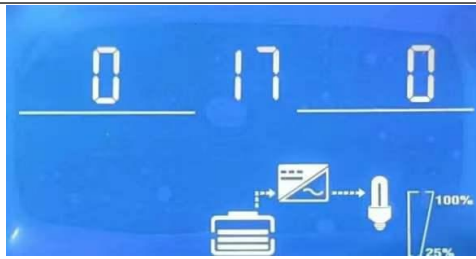



9	P9	Software version.	
10	10	PV generation.	
11	11	"SIG" displayed on the right indicates that the inverter is not parallel-connected. "PAR" displayed on the right indicates that multiple inverters are parallel-connected.	
12	12	"SIG" displayed on the right indicates that the lithium battery is running in a single group. "PAR" displayed on the right indicates that multiple lithium battery groups are parallel-connected.	
13	13	The voltage and current of a lithium-ion battery depend on its usage status and the type of connection.	
14	14	The temperature and State of Charge (SOC) of a lithium-ion battery have important effects on its performance and lifespan.	
15	15	The left side represents the rated capacity, while the right side displays the current remaining capacity of the lithium-ion battery.	



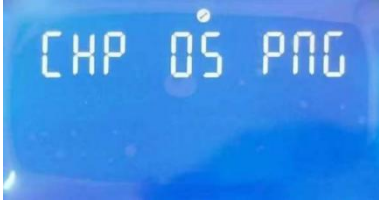

16	16	Constant voltage charging voltage of lithium battery	
17	17	Alarm and fault information of lithium battery: On the left side are the alarm messages, and on the right side are the fault messages.	



Note: Any questions about communicating with BMS, please consult with manufacturer.

4.3 Other feature descriptions.

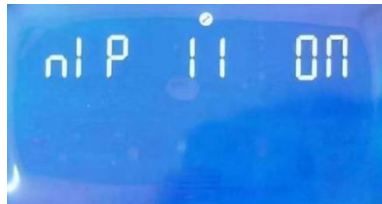

Press ENTER for more than 2 seconds to enter the setting screen. Select a setting item through UP or DOWN. After selecting a setting item, press 0.1 to 2S to enter the setting state of the corresponding item			
1	01	"Output voltage (OPU) The default value for the output voltage is 230V, 208V, and 220V. It can be set to 230V and 240V, and can be set for all conditions, taking effect immediately. When the output voltage is 208V, the output power is reduced by about 90%."	
2	02	2 "Output frequency (OPF) The default is 50Hz, and 50Hz and 60Hz can be set. It can be set for all states, and the setting will take effect the next time the machine is restarted in battery mode, or immediately in mains mode. After the setting is completed, when the machine switches back to battery mode, the frequency will change slowly."	
3	03	"Output priority (OPP) Inverter output priority status setting. There are three priority options, with GRD being the default: GRD, priority for mains output. PU, priority for PV solar output. PBG, priority for PV solar, battery, and mains output at the same time. It can be set for all states, and the setting takes effect immediately."	



4	04	<p>"Output mode (MOD) Inverter AC output mode selection. APP is the default mode: Mode 1 APP: Appliance mode for home appliances, with a typical switching time of 20ms. Mode 2 UPS: UPS mode for computers and other devices, with a typical switching time of 10ms. It can be set for all states, and the setting takes effect immediately."</p>	
5	05	<p>"Charging priority (CHP) Battery charging priority setting. There is one charging priority option, PNG being the default: PNG(PV and Grid): PV and Grid charging at the same time. OPV(Only PV): Only PV solar charging. GRD(Grid): Mains charging priority charging. PV: PV solar priority charging. It can be set for all states, and the setting takes effect immediately."</p>	
6	06	<p>"Mains charging current (RCC) Setting the maximum mains chargeable current for the inverter. RCC: Grid Charge Current, with the default maximum mains charging current being 40A. The setting range for 3KW is 2A-60A. The setting range for 5KW is 2A-80A. It can be set for all states, and the setting takes effect immediately."</p>	
7	07	<p>"Maximum charging current (MCC) Setting the maximum charge current for the inverter. MCC: Maximum Charge Current refers to the maximum value of PV and mains charging together. The setting range for 3KW is as follows: 2/10/20/30/40/50/60/70/80A/90/100/110/120A. The setting range for 5KW is as follows: 2/10/20/30/40/50/60/70/80A. It can be set for all states, and the setting takes effect immediately."</p>	
8	08	<p>"Menu default (MDF) Return to the main menu setting. The default setting is ON. During the function setting operation, if it is set to ON and the page is not on the main menu (P1), it will return to the main menu after 1 minute. If it is set to OFF, the LCD will stay on this screen if the page is not on the main menu (P1). It can be set for all states, and the setting takes effect immediately."</p>	



9	09	<p>"Overload restart (LrS) Setting for whether to restart after overload protection. The default setting for overload restart is ON. It can be set for all states, and the setting takes effect immediately."</p>	
10	10	<p>"Over-temperature restart (TrS) Setting for whether to restart after over-temperature protection. The default setting for over-temperature restart is ON. It can be set for all states, and the setting takes effect immediately."</p>	
11	11	<p>Main Input Power (MIP) Failure Alarm Setting for long alarm of power loss detection on mains or PV. MIP: Main Input Power Failure Alarm. Default setting is ON. When setting is ON, the buzzer will beep continuously for 3s after detecting power loss on the main input. When the setting is OFF, the buzzer will not beep after detecting main input power loss. All states can be set, and changes take effect immediately.</p>	
12	12	<p>Power Saving Mode (PWS) Setting for enabling low power mode in the inverter. PWS: Power Saving Mode. Default setting is OFF. When setting is ON, in battery mode, when the load is less than 25W, the system will briefly stop the output before continuing output. If the load exceeds 35W, the system will resume normal output. When the setting is OFF, this feature is not available. All states can be set, and changes take effect immediately.</p>	
13	13	<p>Overload to Bypass (OLG) Setting for automatically switching to mains mode when in battery mode and an overload is detected. OLG: Overload to Bypass. Default setting is OFF, and this feature is not available. When setting is ON, in a PV priority load situation, when an overload is detected, the system will immediately switch to bypass mode (i.e. mains output). All states can be set, and changes take effect immediately.</p>	



14	14	<p>Mute (MUE) Setting for disabling the buzzer. MUE: Mute. Default setting is OFF, and this feature is not available. When setting is ON, in any state such as alarm or fault, the buzzer will not sound. All states can be set, and changes take effect immediately.</p>	
15	15	<p>Back to Grid (BTG) Setting for switching to mains power when battery and mains are available, to prevent the battery from being discharged. BTG: Back to Grid. The initial default for 3KW is 23V, and for 5KW, it is 46V. For CUS mode batteries: 3KW can be set between [22,26]. 5KW can be set between [44,52]. For AGM or FLD batteries: 3KW defaults to 23V, and can be set between [22,26]. 5KW defaults to 46V, and can be set between [44,52]. For LIB batteries: 3KW defaults to 23.8V, and can be set between [20,25]. 5KW defaults to 47.6V, and can be set between [40,50]. All states can be set, and changes take effect immediately.</p>	
16	16	<p>Back to Battery (BTB) Setting for the minimum battery voltage required to reactivate the battery mode after a low power shutdown. BTB: Back to Battery. The initial default for 3KW is 26V, and for 5KW, it is 52V. When set to FUL, the battery will be charged to full before reactivating the battery mode. For CUS mode batteries: 3KW range is [24,29]. When the setting value $V_{btb} > TCFV - 1V$, the voltage point for back to battery mode is kept at $TCFV - 1V$. If the battery voltage is higher than $TCFV - 1V$ and it is not in battery mode when the PV priority output or PV and battery to grid (PBG) output, the system will switch back to battery mode. 5KW range is [48,58]. The logic is the same as for 3KW. For AGM or FLD batteries: Default setting for 3KW is 26V. Range is [24,29]. Same logic as CUS mode batteries. Default setting for 5KW is 52V. Range is [48,58]. Same logic as CUS mode batteries. For LIB batteries: Default setting for 3KW is 27.2V. Range is [23,29]. Same logic as CUS mode batteries. Default setting for 5KW is 54.4V. Range is [46,58]. Same logic</p>	



		<p>as CUS mode batteries. All states can be set, and changes take effect immediately.</p>	
17	17	<p>Battery Type (BAT)</p> <p>Setting for the battery type.</p> <p>BAT: Battery Type. There are four battery types available: AGM, FLD, LIB, and CUS (custom set type). The default setting is AGM. When setting is LIB, the inverter will not turn off the screen while in standby mode after activation.</p> <p>All states can be set, and changes take effect immediately.</p>	
18	18	<p>Battery Low Point (BAL)</p> <p>Setting for the battery low point warning.</p> <p>BAL: Battery Low. This setting cannot be modified in AGM (lead-acid battery) and FLD (maintenance-free battery) modes. The initial default for 3KW is 21.6V, and for 5KW, it is 44V. When the battery type is set to CUS (custom set type), the battery low point can be modified. The range for 3KW can be set from [21,27]. The range for 5KW can be set from [42,54].</p> <p>When the battery type is set to LIB (lithium battery type), the battery low point can be modified. The default setting for 3KW is 23.8V, and the range can be set from [20.6,25.0]. The default setting for 5KW is 47.6V, and the range can be set from [41.2,50.0].</p> <p>3. All states can be set, and changes take effect immediately.</p>	



19	19	<p>Battery Under Shut Off (BAU) Setting for the battery under shut off point. BAU: Battery Under.</p> <p>This setting cannot be modified in AGM (lead-acid battery) and FLD (maintenance-free battery) modes.</p> <p>The initial default for 3KW is 21V, and for 5KW, it is 42V.</p> <p>When the battery type is set to CUS (custom set type), the shut off point can be modified.</p> <p>The range of 3KW can be set from [20,24]. The range of 5KW can be set from [40,48].</p> <p>When the battery type is set to LIB (lithium battery type), the shut off point can be modified.</p> <p>The default setting for 3KW is 23V, and the range can be set from [20,24]. The default setting for 5KW is 46V, and the range can be set from [40,48].</p> <p>All states can be set, and changes take effect immediately.</p>	
20	20	<p>Battery Constant Voltage (BCV) Setting for the battery constant voltage for charging. BCV: Battery Constant Voltage.</p> <p>This setting cannot be modified in AGM (lead-acid battery) and FLD (maintenance-free battery) modes.</p> <p>The initial default for 3KW is 28.2V (AGM) and 29V (FLD). The initial default for 5KW is 56.4V (AGM) and 58V (FLD).</p> <p>When the battery type is set to CUS (custom set type), the constant voltage for charging can be modified.</p> <p>The range for 3KW can be set from [24,29]. The constant voltage should be greater than the floating voltage point. The range for 5KW can be set from [48,60]. The constant voltage should be greater than the floating voltage point.</p> <p>When the battery type is set to LIB (lithium battery type), the constant voltage for charging can be modified.</p> <p>The default setting for 3KW is 28.2, and the range can be set from [25,29]. The constant voltage should be greater than the floating voltage point. The default setting for 5KW is 56.4, and the range can be set from [48,60]. The constant voltage should be greater than the floating voltage point.</p> <p>3. All states can be set, and changes take effect immediately.</p>	

21	21	<p>Battery Float Point (BFL)</p> <p>Setting for the battery float point.</p> <p>BFL: Battery Float.</p> <p>This setting cannot be modified in AGM (lead-acid battery) and FLD (maintenance-free battery) modes.</p> <p>The initial default for 3KW is 27V, and for 5KW, it is 54V.</p> <p>When the battery type is set to CUS (custom set type), the battery float point can be modified.</p> <p>The range for 3KW-24V can be set from [26.6,27.8]. The constant voltage should be greater than the float voltage point.</p> <p>The range for 5KW-48V can be set from [48,60]. The constant voltage should be greater than the float voltage point.</p> <p>When the battery type is set to LIB (lithium battery type), the battery float point can be modified.</p> <p>The default setting for 3KW-24V is 27.6V, and the range can be set from [24,28]. The constant voltage should be greater than the float voltage point.</p> <p>The default setting for 5KW-48V is 55.2V, and the range can be set from [50,58]. The constant voltage should be greater than the float voltage point.</p> <p>3. All states can be set, and changes take effect immediately.</p>	
22	22	<p>"Fault information exists on the battery BMS</p> <p>Disable the BMS communication function or recover after the BMS fault is rectified</p> <p>Applicable model: 3KW/5KW"" mains low voltagepoint (LLV)</p> <ol style="list-style-type: none"> 1. Set the mains low voltage protection point 2. Setting conditions: The inverter is in APP and UPS mode and can be set in any state. 3. LLV: Line Low Voltage <p>In inverter mode</p> <p>Output mode: MOD needs to be set to APP, mains low voltage point setting, default setting is 154V, configurable range is [90,154].</p> <p>Output mode: MOD needs to be set to UPS, and the mains low point is set. The default value is 185V. The value range is 170,200.</p> <p>4. All states can be set and take effect immediately after setting."</p>	

23	23	<p>Line High Voltage (LHV) Setting for the line high voltage protection point. LHV: Line High Voltage. In inverter mode (output mode: MOD needs to be set to APP), the line high voltage protection point can be set. The default setting is 264V, and the range can be set from [264,280]. Setting conditions: The inverter is in APP mode. All states can be set.</p>	
24	24	<p>Low Watt Discharge (LWD) The low watt discharge protection function is used so that when the battery is in a low load state, unlimited discharge time may cause the battery to discharge to a very low level, affecting the battery life. When the inverter is set to a low watt discharge time, the low voltage shutdown point for 3KW batteries is increased to 22V, and for 5KW batteries, it is increased to 44V. LWD: Low Watt Discharge. In inverter mode, the low watt discharge time can be set. The default is 8 (8 hours), and the range can be set from [1, 8]. In battery mode, if the discharge time exceeds 8 hours and has not reached the battery shutdown point, the battery voltage shutdown point will be changed to 11Vnumber of battery cells. When the battery continues to discharge to a voltage of 11Vnumber of battery cells, the system will sound an alarm for 1 minute and then shut down. When the battery voltage exceeds 13.2V*number of battery cells for more than 30 seconds, the battery discharge time will be reset. Setting conditions: The inverter is in APP mode. All states can be set.</p>	
25	25	<p>Soft Relay Enable (SRE) When this interface is turned ON, the inverter output gradually increases from 0 to the target voltage value. When this interface is turned OFF, the inverter output increases directly from 0 to the target voltage value. SRE: Soft Relay Enable. The default setting is OFF, and the inverter voltage only closes the output switch after rising to the rated output. If set to ON, the output switch will be closed before the inverter starts to voltage boost. Setting conditions: Can be set in standalone mode.</p>	

26	26	<p>Set Default (STD)</p> <p>Resets all settings to the default values.</p> <p>STD: Set Default.</p> <p>Before setting, this interface displays OFF. When set to ON, the system will restore default settings. After the setting is completed, this interface will show OFF again.</p> <p>Setting conditions: Available for setting in mains mode and standby (StandBy: no output but screen on) modes. Cannot be set in battery mode.</p>	
27	27	<p>Parallel Operation Mode (PAM)</p> <p>Set the parallel operation mode.</p> <p>PAM: Parallel operation mode.</p> <p>The default setting is SIG (single mode), which can be set to PAR (single-phase paralleling mode), 3P1 (R phase mode), 3P2 (S phase mode), or 3P3 (T phase mode).</p> <p>When using the parallel operation function, connect the parallel system in the correct way and set the parallel operation mode for each machine correctly. If there is a machine in the parallel system that is set to SIG, the machine will report a fault code 24. If there are machines set to 3P1, 3P2, or 3P3 in the parallel system, all machines must be set to at least one of these three modes, and there must be at least one machine for each mode, otherwise, all machines set to these three modes will report a fault code 24.</p> <p>Setting conditions: Can be set in mains mode and standby (StandBy: no output but screen on) modes for 5KW models. Cannot be set in battery mode or for other models.</p>	
28	28	<p>Set Battery Alarm (SBA)</p> <p>Set to enable the battery alarm for unconnected battery.</p> <p>SBA: Set battery alarm.</p> <p>The default setting is OFF.</p> <p>If set to OFF, there will be no battery alarm for unconnected battery, low voltage, or under-voltage.</p> <p>This can be set in standalone mode for 5KW models, but cannot be set for other models.</p> <p>Setting conditions: Can be set in all modes.</p>	

35	35	<p>Grid Tie Inverter (GTI)</p> <p>Set whether the inverter feeds power into the grid in PV priority mains mode or PBG mains mode.</p> <p>GTI: Grid Tie Inverter.</p> <p>The default setting is OFF, and the function is not enabled.</p> <p>When set to ON, the inverter performs maximum power point tracking and feeds excess energy into the grid.</p> <p>After the function is enabled, if a communication abnormality occurs, alarm code 56 will be generated, and the inverter will no longer operate according to BMS information.</p> <p>Setting conditions: Can be set in all modes.</p>	
38	38	<p>BMS Communication (BMS)</p> <p>Set whether the inverter communicates with the lithium battery BMS.</p> <p>BMS: Battery Management System.</p> <p>The default setting is OFF, and the function is not enabled.</p> <p>When set to ON, the inverter communicates with the lithium battery BMS through the central control panel and obtains battery information.</p> <p>After the function is enabled, if a communication abnormality occurs, alarm code 56 will be generated, and the inverter will no longer operate according to the BMS information.</p> <p>Setting conditions: Can be set in all modes.</p>	
39	39	<p>Low SOC Shutdown (SBU)</p> <p>Set whether the inverter shuts down when the battery SOC is low.</p> <p>SBU: Battery SOC under lock.</p> <p>The default setting is 20, and the adjustable range is [5,50].</p> <p>When the lithium battery SOC reaches the set value in battery mode, the inverter will shut down and alarm code 68 will be generated. The alarm code will be cleared when the SOC reaches the set value + 5%. When in standby mode, the inverter can switch to battery mode only when the SOC is at the set value + 10%. Alarm code 69 will be generated when the SOC is not reached. After the function is enabled, alarm code 69 will be generated when the lithium battery SOC reaches the set value + 5%, and the alarm code will be cleared when the SOC reaches the set value + 10%.</p> <p>The function can be set to OFF, in which case the inverter will not shut down, start up or generate alarms based on SOC conditions.</p> <p>After the function is enabled, if a communication abnormality occurs, the inverter will no longer operate according to SOC information, and the relevant alarms will be cleared.</p>	

		Setting conditions: Can be set in all modes.	
40	40	<p>High SOC Turn to Battery Function (STB)</p> <p>Set the SOC value for the inverter to switch to battery mode. STB: Battery SOC turn to battery mode.</p> <p>The default setting is 90, and the adjustable range is [10,100]. When the lithium battery SOC reaches the set value in PBG priority mains normal mains mode, the inverter switches to battery mode. After the function is enabled, the inverter will only switch to battery mode when the SOC is higher than the set point and the battery voltage is higher than the voltage point for switching back to battery mode.</p> <p>The function can be set to OFF, in which case the inverter will no longer switch from mains mode to battery mode based on SOC conditions.</p> <p>After the function is enabled, if a communication abnormality occurs, the inverter will no longer operate according to SOC information and the relevant alarms will be cleared.</p> <p>Setting conditions: Can be set in all modes.</p>	
41	41	<p>Low SOC Turn to Grid Function (STG)</p> <p>Set the SOC value for the inverter to switch to mains mode. STG: Battery SOC turn to grid mode.</p> <p>The default setting is 50, and the adjustable range is [10,90]. When the lithium battery SOC reaches the set value in PBG priority mains normal battery mode, the inverter switches to mains mode. After the function is enabled, the inverter will switch to mains mode when the SOC is lower than the set point or the battery voltage is lower than the voltage point for switching back to mains mode.</p> <p>The function can be set to OFF, in which case the inverter will no longer switch from battery mode to mains mode based on SOC conditions.</p> <p>After the function is enabled, if a communication abnormality occurs, the inverter will no longer operate according to SOC information and the relevant alarms will be cleared.</p> <p>When the setting is higher than the STB point, STB and STG will no longer take effect after the next activation.</p> <p>Setting conditions: Can be set in all modes.</p>	

4.4 Display Information

The LCD display information will be switched in turns by pressing “UP” or “DOWN” key. The selectable information is switched as below order: voltage, frequency, current, power, firmware version.

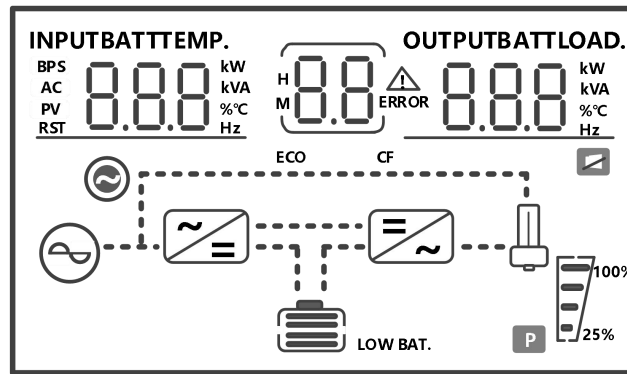

Setting Information	LCD display
① AC Input voltage ② Output voltage ③ Load percentage ④ PV input voltage ⑤ Battery voltage ⑥ Warning or Fault code (Default Display Screen)	
① AC Input frequency ② Output frequency ③ Load power in VA ④ PV energy sum in KWh ⑤ Battery percentage ⑥ Warning or Fault code	
① AC Input current ② Output current ③ Load percentage ④ PV input current ⑤ Battery charging current ⑥ Warning or Fault code	
① AC input power in Watts ② Inverter temperature ③ Load power in Watts ④ PV energy sum in KWh ⑤ Battery percentage ⑥ Warning or Fault code	
Firmware version (CPU1: 040-00-b21; CPU2:041-00-b21)	
Time (15:20:10, December 15, 2018)	

4.5 Operating Mode Description

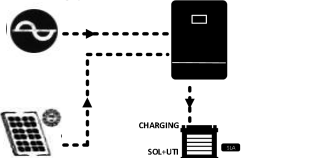
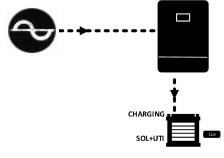
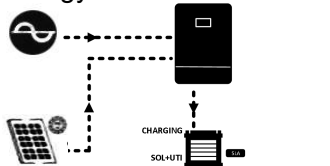
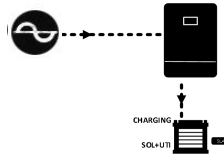
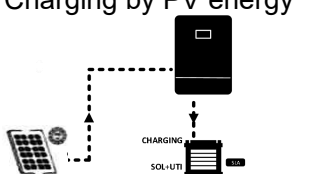
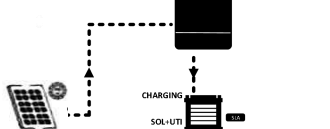
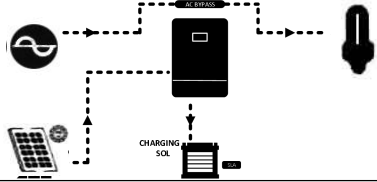
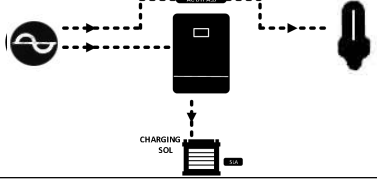
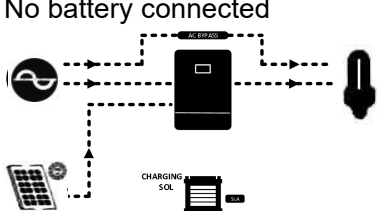
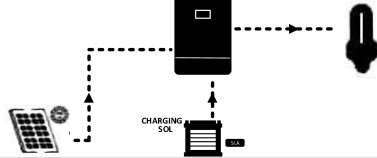
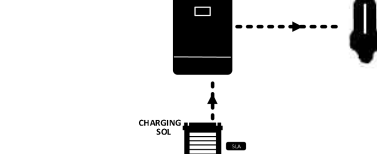
Operation mode	Description	LCD display	
<p>Standby mode / Power saving mode</p> <p>Note: *Standby mode: The inverter is not turned on yet but at this time, the inverter can charge battery without AC output.</p> <p>*Power saving mode: If enabled, the output of inverter will be off when connected load is pretty low or not detected.</p>	<p>No output is supplied by the unit but it still can charge batteries.</p>	<p>Charging by utility and PV energy.</p> 	<p>Charging by utility</p> 
<p>Fault mode Note: *Fault mode: Errors are caused by inside circuit error or external reasons such as over temperature, output short circuited and so on.</p>	<p>PV energy and utility can charge batteries.</p>	<p>Charging by utility and PV energy.</p> 	<p>Charging by utility</p> 
<p>Charging by PV energy</p> 	<p>No charging</p>	<p>Charging by PV energy</p> 	<p>No charging</p>
<p>Line Mode</p>	<p>The unit will provide output power from the mains. It can also charge the battery at line mode.</p>	<p>Charging by PV energy</p> 	<p>Charging by Utility</p> 
<p>No battery connected</p> 	<p>The unit will provide output power from battery and PV power.</p>	<p>Power from battery and PV energy</p> 	<p>Power from battery only</p> 

4.6 Warning Indicator

Fault Code	Fault Event	Fault description
01	Bus soft start fail	During soft start of the bus, the set voltage cannot be reached and cannot be recovered. This issue applies to the 3KW/5KW model.
02	Bus voltage high	The bus voltage is higher than the set value and cannot be recovered. This issue applies to the 3KW/5KW model.
03	Bus voltage low	"The bus voltage is below the set value unrecoverable Applicable model: 3KW/5KW"
04	Battery Over Current	"Battery current transient value exceeds 580A, immediately protect unrecoverable Applicable model: 3KW/5KW" "The PFC or INV temperature sensor exceeds the temperature set value After the restart function is enabled, the fault cannot be recovered after six failed restarts Applicable model: 3KW/5KW"
05	Over Temperature	The PFC or INV temperature sensor is higher than the temperature set value After the restart function is enabled, the fault cannot be recovered after six failed restarts Applicable model: 3KW/5KW
06	Battery voltage high	The battery voltage is above the set value recoverable Applicable model: 3KW/5KW"
07	Bus softstart Fault	"The bus DC soft starting voltage does not reach the set value unrecoverable Applicable model: 3KW/5KW"
08	Bus Short Fault	When working normally, the bus bar is below the set value instantly unrecoverable Applicable model: 3KW/5KW
09	INV Soft Fault	"After a period of soft startup of the inverter, either cannot reach the rated output voltage unrecoverable Applicable model: 3KW/5KW"

10	INV Over Voltage	"In battery mode, the inverter voltage is above the set value unrecoverable Applicable model: 3KW/5KW"
11	INV Under Voltage	"In battery mode, the inverter voltage is below the set value unrecoverable Applicable model: 3KW/5KW"
12	INV Short	The inverter voltage is momentarily less than the set value, and the current is momentarily greater than the set value The fault cannot be recovered after six failed restarts Applicable model: 3KW/5KW"
13	Negative Power	"The inverter power is below the set value for a period of time unrecoverable Applicable model: 3KW/5KW"
14	Overload Fault	"Load is out of specification The fault cannot be recovered after six failed restarts Applicable model: 3KW/5KW"
15	Model Fault	Software identification machine type does not match hardware detection unrecoverable Applicable model: 3KW/5KW"
16	No Bootloader	No bootstrap unrecoverable Applicable model: 3KW/5KW"
17	MPPT Programmer Burning	The machine is burning the PV control program Resume after burning Applicable model: 3KW/5KW"
19	Same Serial	In parallel mode, multiple machines with the same serial number are detected unrecoverable Applicable model: 3KW/5KW"
20	CAN Fault	"In parallel mode, CAN bus communication is abnormal unrecoverable Applicable model: 3KW/5KW"

4.7 Fault Reference Code

Alarm code	Alarm name	Alarm description
50	Battery Open	"The battery voltage is below 8V/ knot The battery voltage can be recovered up to 10V/ knot Applicable model: 3KW/5KW"
51	Battery Under Voltage	"Battery voltage less than 10.5V/ knot (default) Battery voltage 10V/ knot +0.2*N recoverable Applicable model: 3KW/5KW"
52	Battery voltage low	"Based on the bAL set point unrecoverable Applicable model: 3KW/5KW"
53	Battery Charge Short	"The battery voltage is less than 5V and the charging current is greater than 4A unrecoverable Applicable model: 3KW/5KW"
54	Low Watt Discharge	"The battery discharge exceeds the set low-power discharge time The battery voltage higher than 13.2V/ node can be recovered Applicable model: 3KW/5KW"
55	Battery Over Charge	"The battery voltage is above the set value recoverable Applicable model: 3KW/5KW"
56	BMS Loss	"Communication failed after BMS communication was enabled recoverable Applicable model: 3KW/5KW"
57	Over Temperature	"The PFC or INV temperature sensor is higher than the set value The value below the set value can be restored Applicable model: 3KW/5KW"
58	Fan Lock	"No fan speed signal detected recoverable Applicable model: 3KW/5KW"
59	EEPROM Fail	"EEPROM read and write failed unrecoverable Applicable model: 3KW/5KW"
60	Over Load Warning	"The load is greater than 102% Recoverable (load less than 97%) Applicable model: 3KW/5KW"

61	Generator Waveform Abnormal	"Abnormal generator waveform detection recoverable Applicable model: 3KW/5KW"
62	PV Energy Weak	When the battery is not connected, the bus voltage is below the set value 10mins Recoverable Applicable model: 3KW/5KW"
63	Synchronization Signal Fail	"Parallel plate disconnected fault Switching to single machine mode can be recovered or line disconnection troubleshooting can be recovered Applicable model: 3KW/5KW"
64	Parallel configuration incompatible	"There is a lack of phase setting when the three phase is combined Restore when the three-phase Settings are correct Applicable model: 3KW/5KW"
65	Parallel version incompatible	"The parallel system has incompatible version numbers Restore when all machine versions in parallel system are compatible with each other Applicable model: 3KW/5KW"
66	Parallel Communication Fault	"Slave cannot be detected in parallel system In the parallel system, the recovery is detected after the slave is connected, and the recovery is set to the single machine mode Applicable model: 3KW/5KW"
67	Parallel Line Differ	"Parallel machine each machine mains voltage or frequency error is too large When the mains voltage and frequency error of each machine is detected, it will be restored Applicable model: 3KW/5KW"
68	Low SOC off	The lithium battery SOC is below the set value Disable low SOC shutdown function, disable BMS communication function, or restore when SOC returns to + 5% of set value Applicable model: 3KW/5KW"
69	Low SOC	When the lithium battery SOC is lower than the set value + 5% (in utility mode or battery mode) or lower than the set value + 10% (in standby mode), the Low SOC shutdown function will be activated. To resolve this, the Low SOC shutdown function can be disabled, or the BMS communication function can be disabled, or the SOC can be restored to the set value + 10%. This issue applies to the 3KW/5KW model.

5. Routine Maintenance

5.1 Maintenance Plan

- ◆ Check if wire connections are loose.
- ◆ Check if cables are aged/damaged.
- ◆ Check if cable insulating ribbon drops.
- ◆ Check if cable terminal is loose, any overheat sign.
- ◆ Check if ground connection is good.

5.1.1 Operating Environment

(Every six months)

Carefully observe whether the battery system equipment is ineffective or damaged;

When the system is running, listen to any part of the system for abnormal noise;

Check whether the voltage, temperature and other parameters of the battery and other equipment parameters are normal during system operation;

5.1.2 Equipment Cleaning

(Every six months to one year, depending on the site environment and dust content, etc.) Ensure that the ground is clean and tidy, keep the maintenance access route unblocked, and ensure that the warning and guiding signs are clear and intact.

Monitor the temperature of the battery module and clean the battery module if necessary.

5.1.3 Cable, Terminal and Equipment Inspection

(Every six months to one year)

- ◆ Check if the cable connections are loose.
- ◆ Check whether the cables are aged / damaged.
- ◆ Check whether the cable tie of the cable has fallen off.
- ◆ Check if the cable terminal screws are loose and the terminal position has any signs of overheating.
- ◆ Check whether the management system of the system equipment, monitoring system and other related equipment are invalid or damaged.
- ◆ Check that the grounding of the equipment is good and the grounding resistance is less than 10 ohms.

5.2 Notes

After the equipment is out of operation, please pay attention to following notes while maintaining :

- ◆ Related safety standards and specifications should be followed in operation and maintenance.
- ◆ Disconnect all the electrical connections so that the equipment would not be powered on.
- ◆ Wait at least 5 minutes after disconnection, so that the residual voltage of the capacitors drops to a safe voltage. Use a multimeter to make sure that the equipment is completely discharged.
- ◆ The equipment should be repaired by professional staff only and it is strictly forbidden for maintenance staff to open equipment modules on their own.
- ◆ Appropriate protective measures should be taken while maintaining, such as insulated gloves, shoes, and anti-noise ear plugs.

- ◆ Life is priceless. Make sure no one would get hurt first.
- ◆ In case of a deep discharge, the battery must be charged to a SOC rate of 30% to 50% if the entire system is static (ie the battery has not been charged for two weeks or more).

Please contact us in time if there are any conditions that could not be explained in the manual.

6. Quality Assurance

When product faults occur during the warranty period, factory or his partner will provide free service or replace the product with a new one.

Evidence

During the warranty period, the customer shall provide the product purchase invoice and date. In addition, the trademark on the product shall be undamaged and legible. Otherwise, factory has the right to refuse to honor the quality guarantee.

Conditions

- ◆ After replacement, unqualified products shall be processed by factory.
- ◆ The customer shall give manufacturer or his partner a reasonable period to repair the faulty device.

Exclusion of Liability

In the following circumstances, manufacturer has the right to refuse to honor the quality guarantee:

- ◆ The free warranty period for the whole machine/components has expired.
- ◆ The device is damaged during transport.
- ◆ The device is incorrectly installed, refitted, or used.
- ◆ The device operates in harsh environment, as described in this manual.
- ◆ The fault or damage is caused by installation, repairs, modification, or disassembly performed by a service provider or personnel not from manufacturer or his authorized partner .
- ◆ The fault or damage is caused by the use of non-standard or non-manufacturer.

components or software.

- ◆ The installation and use range are beyond stipulations of relevant international standards.
- ◆ The damage is caused by unexpected natural factors.

For faulty products in any of above cases, if the customer requests maintenance, paid maintenance service may be provided based on the judgment of manufacturer.

Warranty Card

User Information

Company/User Name:

Address:

Telephone:

Email:

Project installation location:

Product Information

Battery Model:

Serial No:

Invoice Number:

Purchase Date:

Dealer:

Commission date:

Fault/Error Description: