

# SONAR Parallel Installation Guide

## **PART1: Single Phase Parallel System Wiring**

Lux power inverter support "Parallel Connection", which means you can combine multiple inverters together to get bigger back-up power. As parallel model is different from standard one, please make it clear to the distributor if you want a parallel unit. This document is used to show how to set up a parallel system.

### **Step1. Single unit installation**

Install each single phase inverter as user manual. Before installation, please make sure the distance between each inverter meet the requirements of user manual.

### **Step2. Parallel system wiring**

If you paralleling the system as single phase system, the most important thing is to make sure the L & N lines of each unit (AC port And EPS port) are correctly connected, please check with multi-meter to make sure L cable of each units are connected. Do not connect one inverter's L cable to another inverter's N cable.

Wiring the parallel system as below suggestions for safety and cost reasons. Three single phase inverters in parallel diagram:

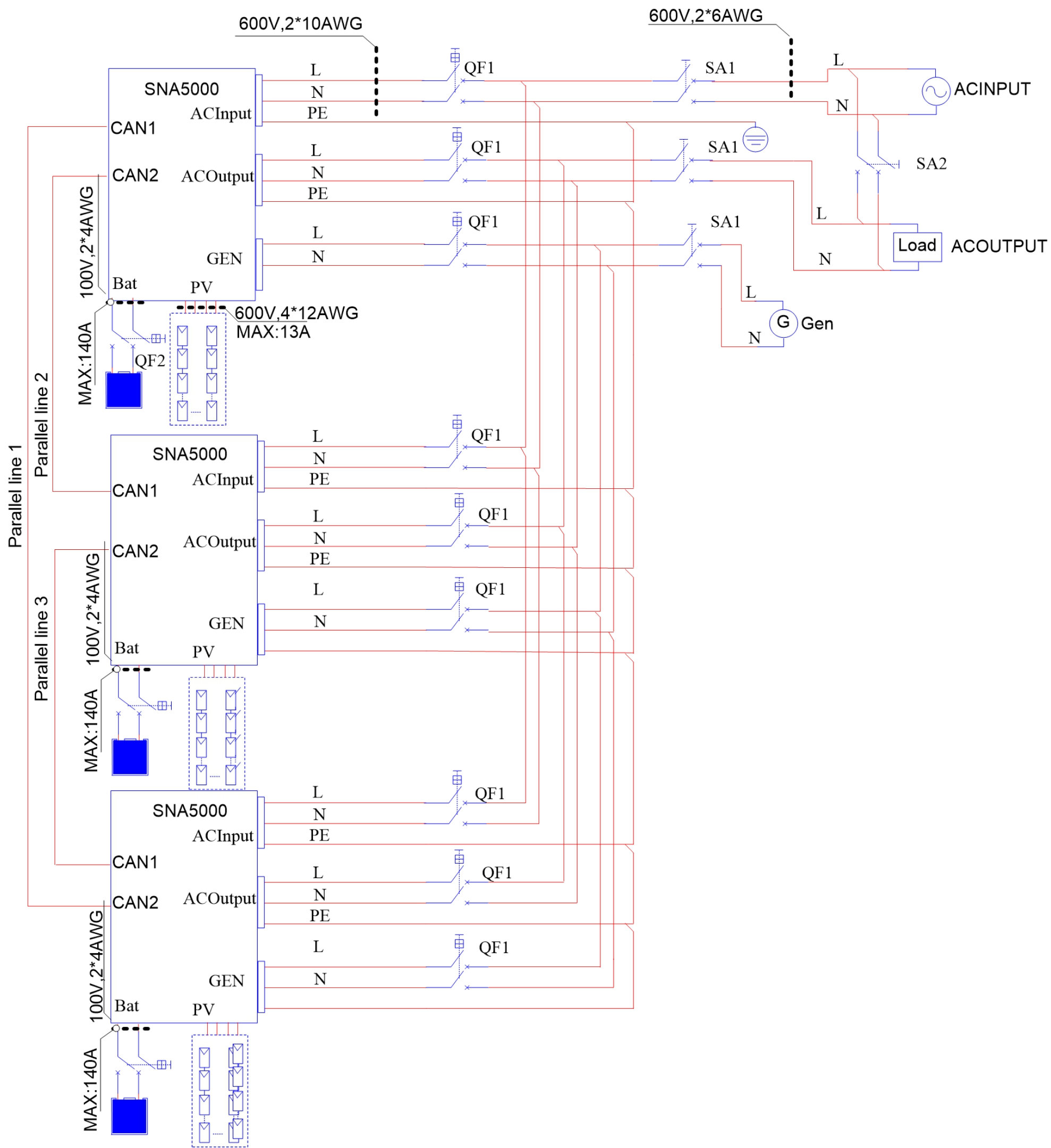

**Not share the battery**



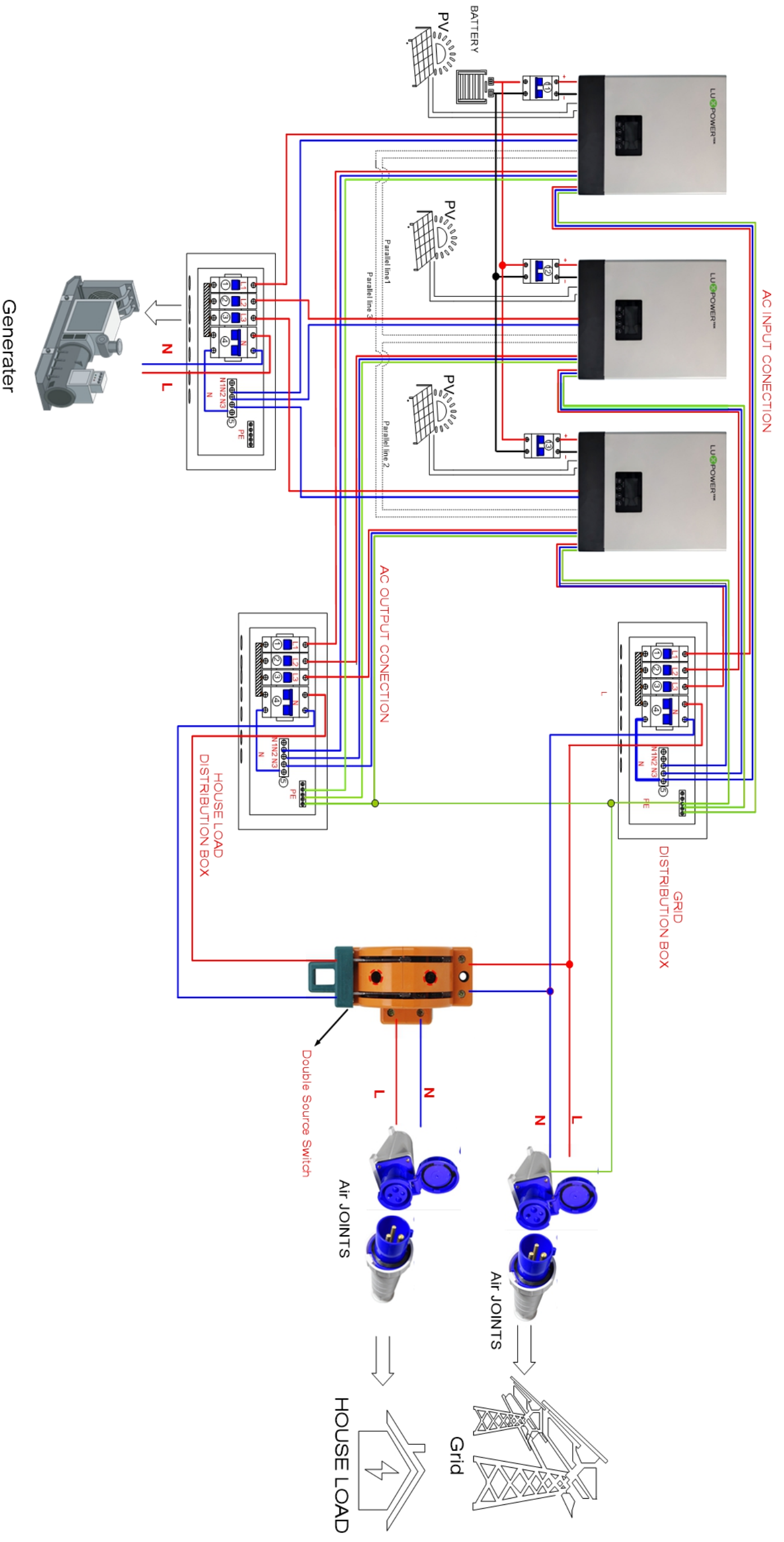

✓ **Recommend Capacity Section of battery:**

Inverter parallel numbers	2	3	4	5	6
Battery Capacity	400AH	600AH	800AH	1000AH	1200AH

**\*At least 200AH per unit**

✓ **Cross Section of connection cable:**



Position	Cross Section (Length ≤ 20m)	Note
AC Input to QF1	≥ 5.26mm <sup>2</sup>	Maximum Grid current is 40A
AC Output to QF1	≥ 5.26mm <sup>2</sup>	Nominal current is 25A
GEN Port to QF1	≥ 5.26mm <sup>2</sup>	Maximum current is 25A
QF1 Port to SA1	≥ 5.26mm <sup>2</sup>	Maximum current is 25A
SA1 to AC	≥ 6mm <sup>2</sup> *3	Maximum current is 40A*n
SA1 to AC	≥ 5.26mm <sup>2</sup> *3	Maximum current is 25A*n
SA1 to AC	≥ 5.26mm <sup>2</sup> *3	Maximum current is 25A*n

**\*\*1) Copper wire 1 mm<sup>2</sup> safe current carrying capacity is 5 amps (within 20 meters distance)**

2) **The PE line can be chosen between 6~10mm<sup>2</sup>**

3) **N means the number of parallel**

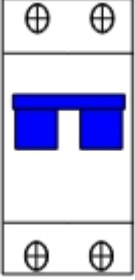
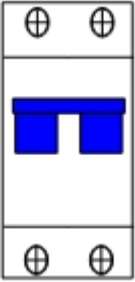
✓ **Breaker section:**

Position	Section	Note
QF1		230Vac
		Maximum AC Input current is 40A
		Maximum AC Output current is 45A (2*5KW Maximum)
QF2		60DC
		The maximum current is 140A
		Maximum GEN Input current is 40A (AC Charge+AC Output Load)
SA1		230Vac/380Vac
		N is the number of parallel units
		Maximum current is 45A (2*5KW Maximum)



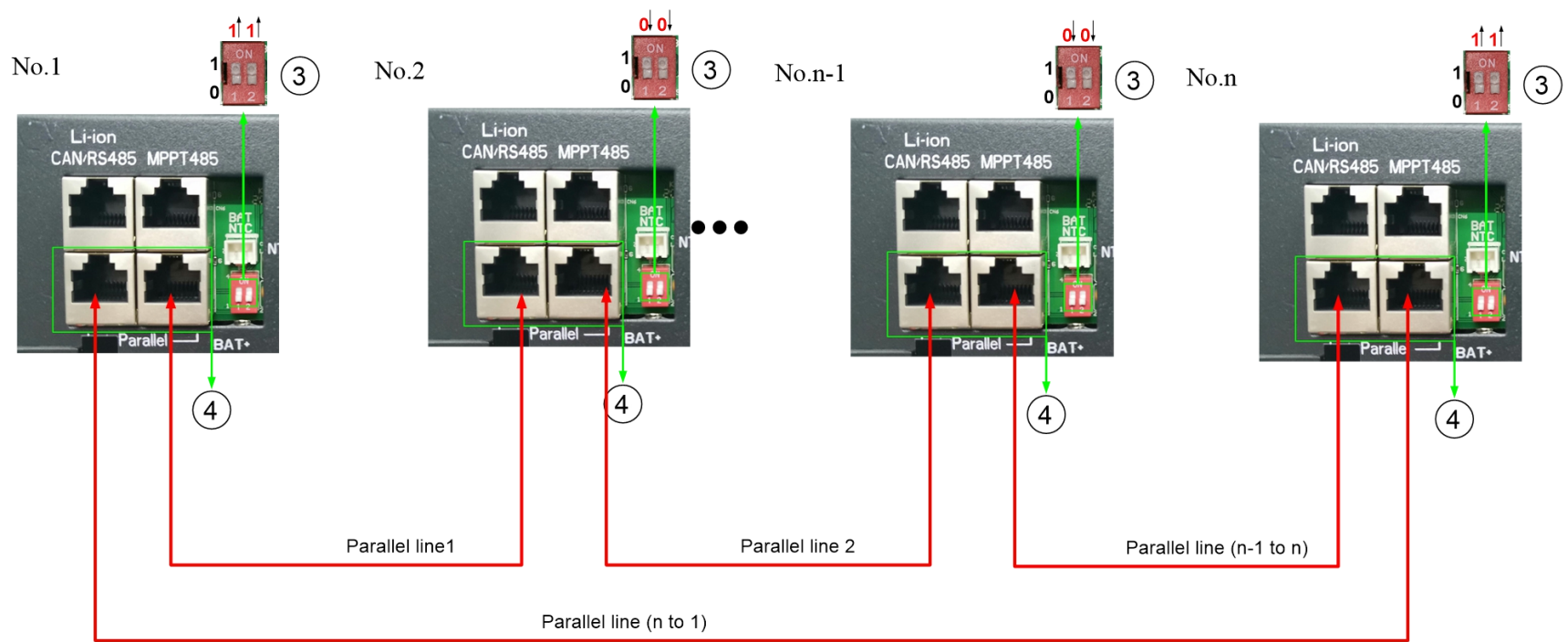

The maximum parallel quantity is 16PCS

- For other ports' definition, please refer to user manual.
- Please double check if the wirings are correct.
- The parallel port are pin-to-pin with each other for PIN1~PIN8, and you can buy this easily in any computer shop



#### ➤ Step4. Set up the monitor system and do settings

- Power on the inverter and connect Wi-Fi to dongle to internet.
- For parallel system battery connection, we support 2 ways to connect, you can either connect all inverters to one battery bank or connect each inverter to separate battery group. Or it is connected as each inverter connctet to separate battery.
- If you connect one battery bank shared by multiple inverters as the diagram above, please enable "Battery shared".

Application Setting

EPS Voltage Set(V) <input type="text" value="208"/> <input type="button" value="Set"/>	EPS Frequency Set(Hz) <input type="text" value="50"/> <input type="button" value="Set"/>	
AC Input Range <input type="text" value="0: APL(Utility Range90-280V 20ms)"/> <input type="button" value="Set"/>		
AC First		
AC first Start Time 1 <input type="text" value="[0, 23]"/> : <input type="text" value="[0, 59]"/> <input type="button" value="Set"/>	AC first Start Time 2 <input type="text" value="[0, 23]"/> : <input type="text" value="[0, 59]"/> <input type="button" value="Set"/>	AC first Start Time 3 <input type="text" value="[0, 23]"/> : <input type="text" value="[0, 59]"/> <input type="button" value="Set"/>
AC first End Time 1 <input type="text" value="[0, 23]"/> : <input type="text" value="[0, 59]"/> <input type="button" value="Set"/>	AC first End Time 2 <input type="text" value="[0, 23]"/> : <input type="text" value="[0, 59]"/> <input type="button" value="Set"/>	AC first End Time 3 <input type="text" value="[0, 23]"/> : <input type="text" value="[0, 59]"/> <input type="button" value="Set"/>
Hybrid Setting		
PV&AC Take Load Jointly <input type="button" value="Enable"/> <input type="button" value="Disable"/>	Export to Grid <input type="button" value="Enable"/> <input type="button" value="Disable"/>	Export Power Percent(%) <input type="text" value="[0, 100]"/> <input type="button" value="Set"/>
Parallel Settings		
Set Master or Slave (?) <input type="text"/> <input type="button" value="Set"/>	Battery Shared <input checked="" type="button" value="Enable"/> <input type="button" value="Disable"/>	
Set Composed Phase (?) <input type="text"/> <input type="button" value="Set"/>		

➤ **Step5. Running the system**

- Check all connection and make sure is correct.
- Power on all Units and Check the all AC output is OK
- Turn on all breakers

## **PART2: Three Phase System Wiring**

### **Step1. Install each single inverter as user manual**

Lux power inverter support three phase system, which means 3 pcs or more inverters can be used to compose a three phase system. Please note that this model is different from the standard one, please make it clear to distributor to get parallel unit. This document is used to show you how to set up a three phase system.

### **Step2. Parallel connection**

Wiring the parallel system as below suggestions for safety and cost reasons.

When paralleling the system as three phase system, make sure there is at least one inverter in each phase. **DO NOT connect** AC Output terminals all together when used in 3 phase system, otherwise you will short the grid/utility.

Three phase system composed by three inverters diagram:

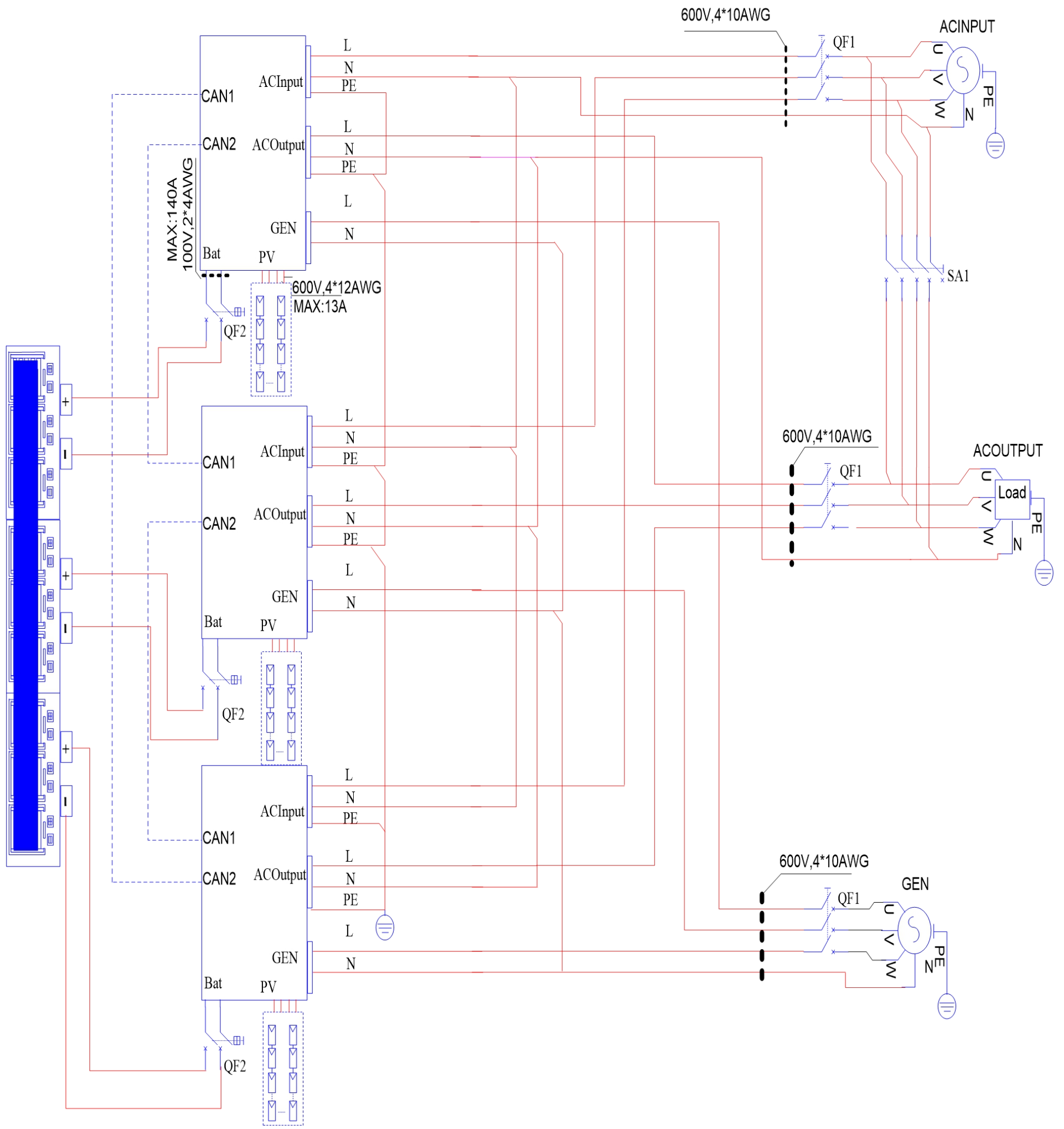

**Must share the battery**

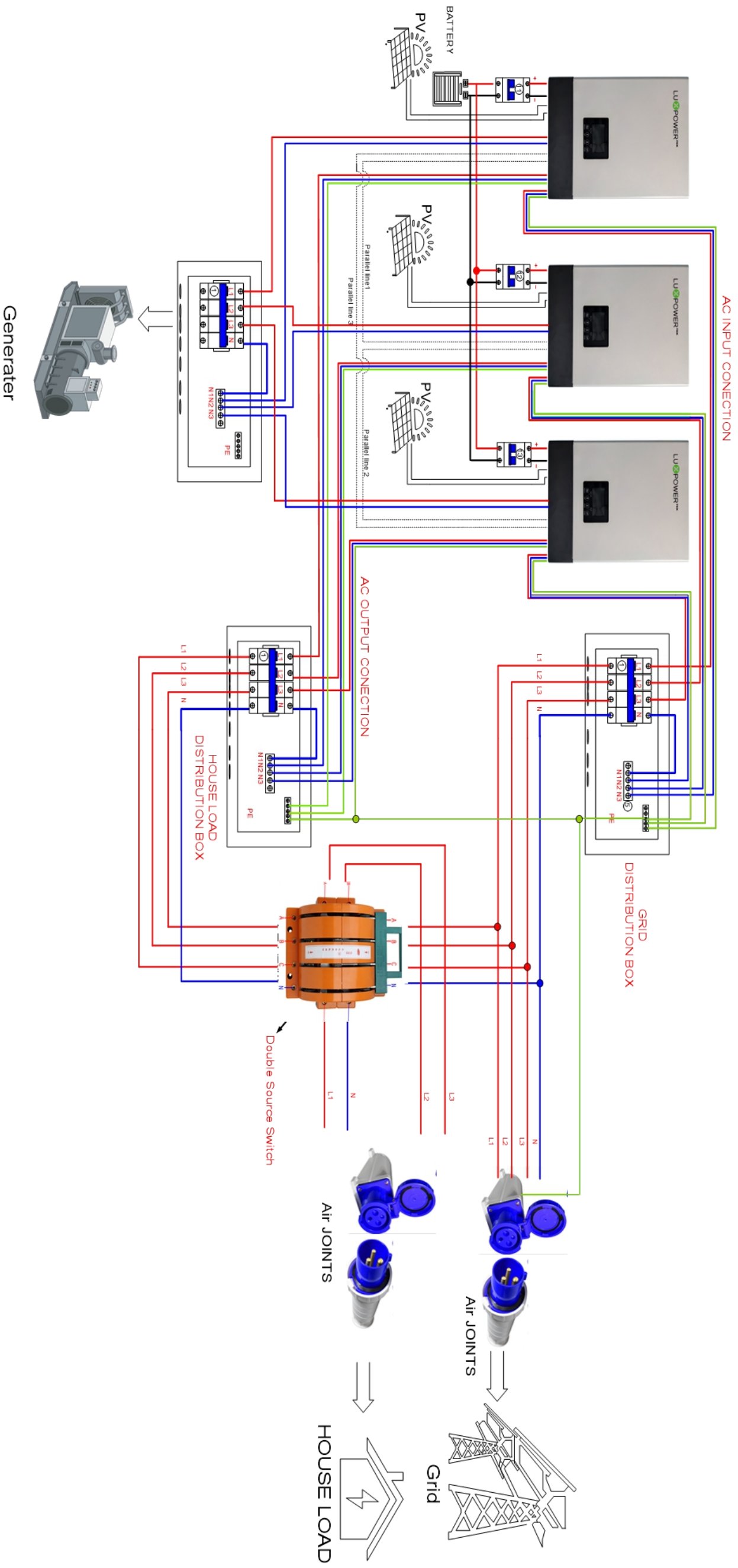

✓ **Recommend Capacity Section of battery:**

Inverter parallel numbers	3	4	5	6
Battery Capacity	600AH	800AH	1000AH	1200AH

\*At least 200AH per unit

✓ **Cross Section of L1,L2,L3&N lines:**

Position	Cross Section (Length ≤ 20m)	Note
AC Input (L1,L2,L3&N) to QF1	≥ 8mm <sup>2</sup>	Maximum Grid current is 40A
AC Output (L1,L2,L3&N) to QF1	≥ 5.26mm <sup>2</sup>	Nominal current is 25A
GEN (L1,L2,L3) to QF1	≥ 8mm <sup>2</sup>	Maximum current is 25A
BATTERY to QF2	≥ 20mm <sup>2</sup>	Maximum current is 25A
AC Input (L1,L2,L3&N) / AC Output (L1,L2,L3&N) to Per SNA5000	≥ 5.26mm <sup>2</sup>	Nominal current is 25A

\*\*1) Copper wire 1 mm<sup>2</sup> safe current carrying capacity is 5 amps (within 20 meters distance) for AC and EPS lines.

2) The PE line can be chosen between 3~4 mm<sup>2</sup>

**!!Be sure the SA1is only used when all inverters is power-off.**

✓ **Breaker section:**

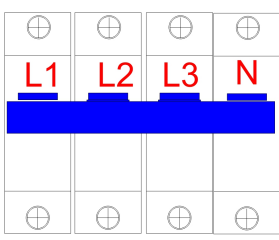
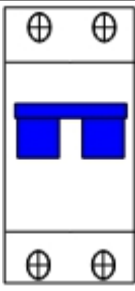
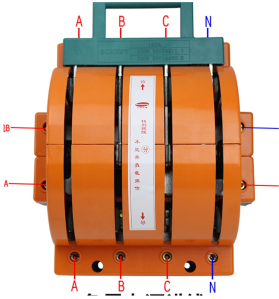
Position	Section	Note
QF1	 230Vac ≥ 23A 3poles	Maximum AC Input current is 40A (AC Charge+AC Output Load) Maximum AC Output current is 23A Maximum GEN Input current is 40A (AC Charge+AC Output Load) N is parallel number per phase
QF2	 60DC ≥ 160A 2poles	Normal Maximum working current is 110A
SA1(DOUBLE SOURCE SWITCH)	 230Vac/380 Vac ≥ 60A 2~3pole	

➤ **Step3. Set up the parallel CAN communication balance resistance.**

- Connect parallel communication cable. The port4 are used for parallel connection.
- Switch ③ are used for the parallel communication balance resistance,

- If there are only three inverters parallel in this three-phase system, Switch③ of No.1 and No.3 need to be dialed toward "on" position: 111, and No.2 keeps off: 001

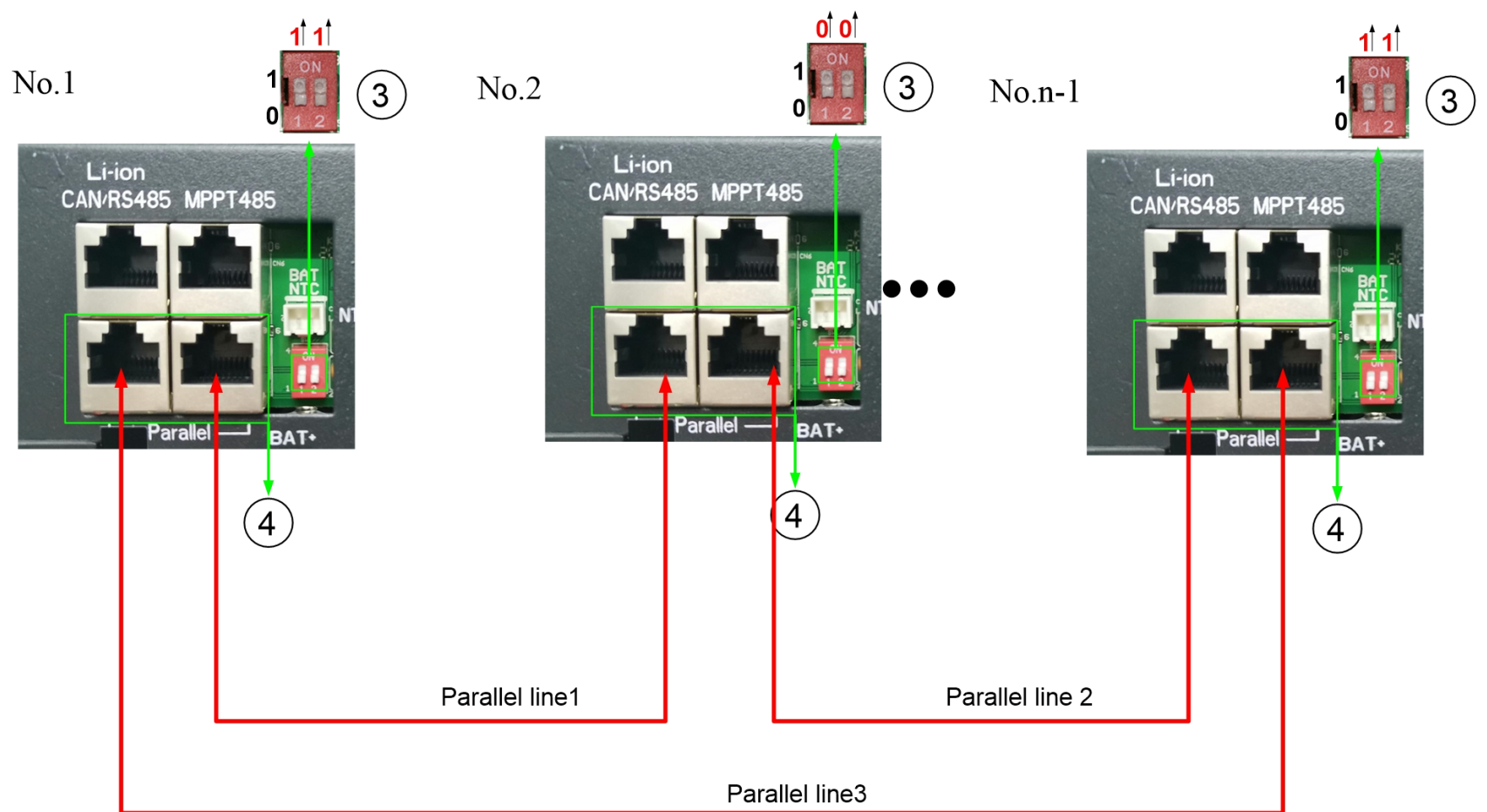

- For other ports' definition, please refer to user manual.
- Please double check if the wirings are correct.
- Please double check if the wirings are correct.
- The parallel port are pin-to-pin with each other for PIN1~PIN8, and you can buy this easily in any computer shop



#### ➤ Step4. Set up the monitor system and do settings

- Power on the inverter and connect Wi-Fi to dongle to internet.
- For parallel system battery connection, we support 2 ways to connect, you can either connect all inverters to one battery bank or connect each inverter to separate battery group. Or it is connected as each inverter connect to separate battery.
- If you connect one battery bank shared by multiple inverters as the diagram above, please

enable "Battery shared".

**Application Setting**

EPS Voltage Set(V) 208 Set      EPS Frequency Set(Hz) 50 Set

AC Input Range 0: APL(Utility Range90-280V 20ms) Set

**AC First**

AC first Start Time 1 [0, 23] : [0, 59] Set      AC first Start Time 2 [0, 23] : [0, 59] Set      AC first Start Time 3 [0, 23] : [0, 59] Set

AC first End Time 1 [0, 23] : [0, 59] Set      AC first End Time 2 [0, 23] : [0, 59] Set      AC first End Time 3 [0, 23] : [0, 59] Set

**Hybrid Setting**

PV&AC Take Load Jointly Enable Disable

Export to Grid Enable Disable      Export Power Percent(%) [0, 100] Set

**Parallel Settings**

Set Master or Slave (?)      Battery Shared **Enable** Disable

Set Composed Phase (?)      Set

### ➤ **Step5. Running the system**

- Check all connection and make sure is correct.
- Power on all Units and Check the all AC output is OK
- Turn on all breakers